

REF DU DOCUMENT : N0790 HY08022017 I30

IFAB112

M.A.J Le :17/11/2017

Indice de modif : C

Nom dessinateur : AS











HYUNDAI I30 & I30N SPORT MODELE 2017
KIT SOCIETE
NOTICE DE MONTAGE

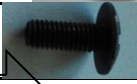

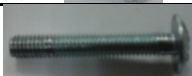
COMPOSITION DU COLIS

| REF | DESIGNATION | QTE |
|---------------|---|--------------|
| S0800 | CONSOLE SUPPORT STRUCTURE | 1G/1D |
| TO0799 | EQUERRE FINITION ARRIERE | 1 |
| TO0801 | CORNIERE AVANT SUPPORT PLANCHER | 1 |
| TO0780 | CORNIERE LATERALE SUPPORT PLANCHER | 2 |
| TO0795 | ENVELOPPE ARRET DE CHARGE | 1 |
| B0803 | PLANCHER | 1 |
| M0804 | MOQUETTE | 1 |
| N0790 | NOTICE DE MONTAGE | 1 |
| V0793 | SACHET VISSERIE (voir compo ci-dessous) | 1 |

Composition du sachet de visserie :

| REF ARTICLE | DESIGNATION | QTE | PHOTO |
|--------------------|--|------------|---|
| POM825 | ANNEAU ARRIMAGE | 2 |  |
| PLO616N | VIS POELIER 6 X 16 N | 7 |  |
| PLOVP6X16 | VIS POELIER 6 X 16 Z | 6 |  |
| PLOVP6X40 | VIS POELIER 6X40 Z | 2 |  |
| FOR925 | VIS FIXATION PLANCHER | 8 |  |
| PLOCL6 | ECROU M6 TENSILOCK | 9 |  |
| S0807 | TIGE FIXATION SUPPORT STRUCTURE | 2 |  |
| NIORET 1234 | BOUCHON OBTURATEUR | 2 |  |
| FOR200 | COLLIER RILSAN | 6 |  |
| SACHET | SACHET PLASTIQUE | 2 |  |

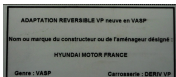
| | | | |
|-------------|---|----------|---|
| //// | Plaque autocollante de transformation VASP | 1 |  |
|-------------|---|----------|---|



KIT SOCIETE ARRET DE CHARGE

**CORNIERE LATERALE SUPPORT
PLANCHER REF TO0780 QTE 2**

ENVELOPPE REF TO0795

CORNIERE AV SUPPORT PLANCHER REF TO0801

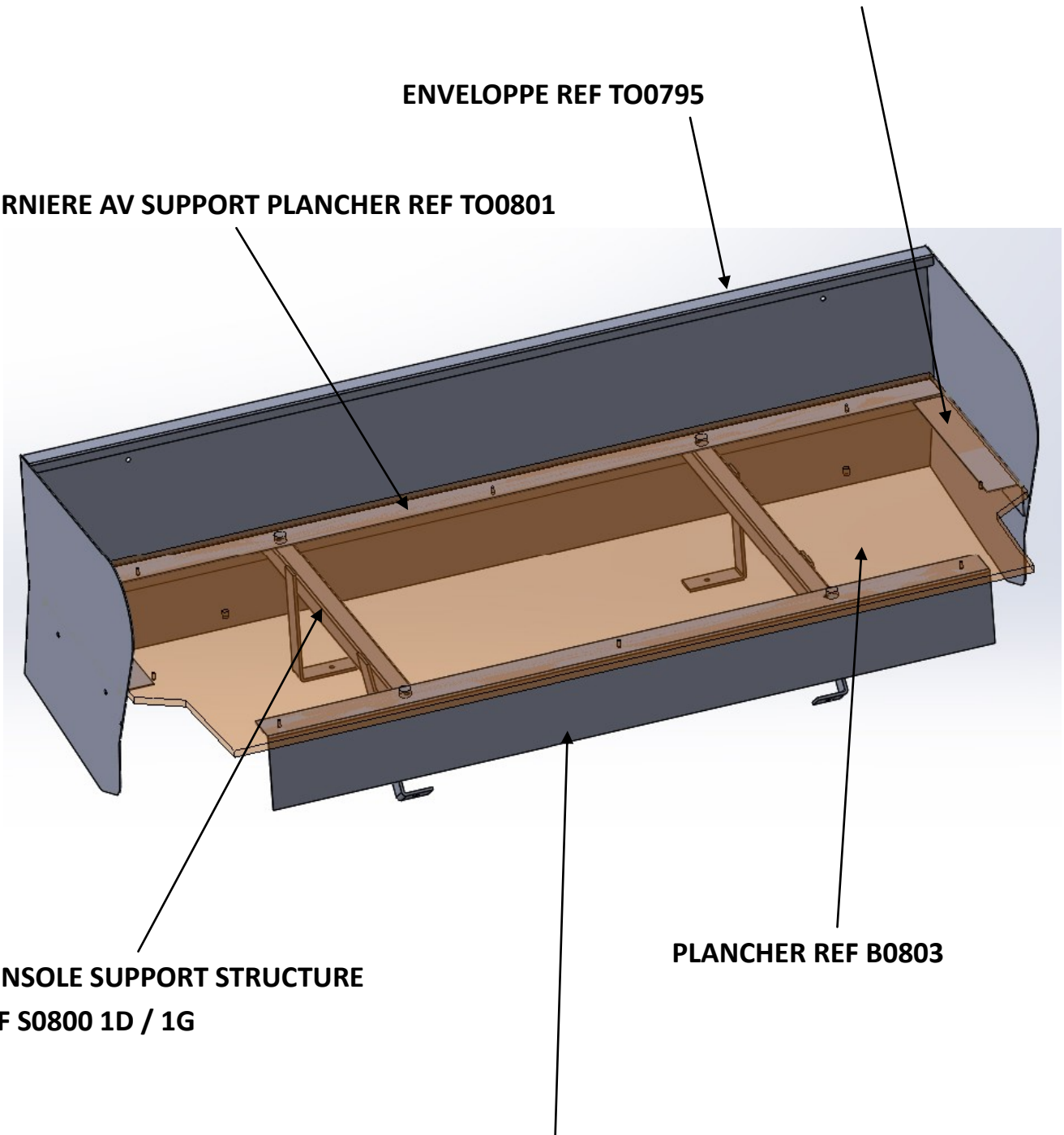

PLANCHER REF B0803

**CONSOLE SUPPORT STRUCTURE
REF S0800 1D / 1G**

EQUERRE FINITION ARRIERE REF TO0799

- 1) Réceptionner le véhicule et vérifier le N° de série .
Placer le véhicule sur une aire de travail propre et stable.
- 2) Contrôler le kit .
- 3) Lire la notice de montage.

ATTENTION :

LA BATTERIE DU VEHICULE DOIT IMPERATIVEMENT ETRE DEBRANCHEE PENDANT LA DUREE DE L'INTERVENTION.

- 4) Démontez les équipements dans l'ordre suivant :
 - a) Démontez la plage arrière



- b) Démontez les assises et les dossiers



L'HABITACLE DOIT ETRE DANS CETTE CONFIGURATION POUR MONTER L'ARRET DE CHARGE

Démontez l'ensemble de fixation des sièges

Attention : Ne pas jeter cet ensemble car il servira lors de la reconversion en VP



c) Conditionner les ceintures



2 x REF MOS229

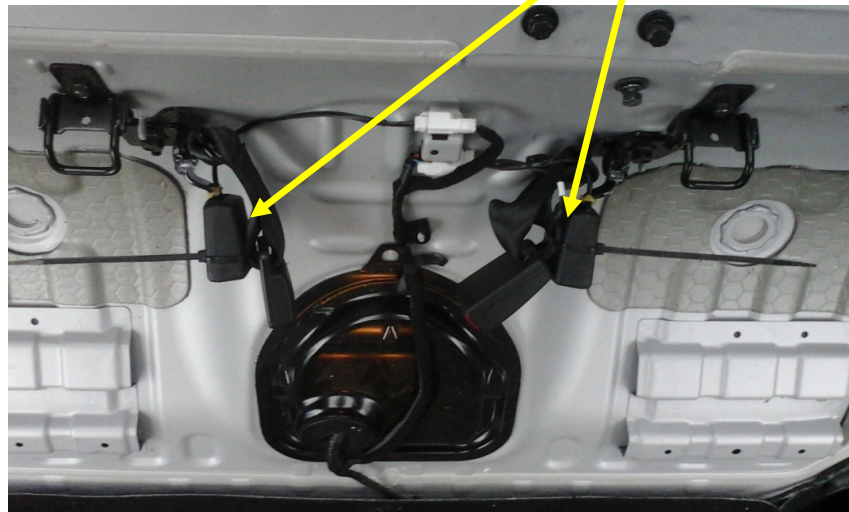

Démonter les enrouleurs non équipés de pretensionneurs. Ne pas démonter ceux avec pretensionneurs équipant certaines versions afin d'éviter le déclenchement intempestif d'alertes permanentes.

ATTENTION .DANS TOUS LES CAS , POUR LE CONDITIONNEMENT DES CEINTURES IL EST IMPERATIF DE LAISSER 50 cm DE GARDE POUR EVITER LE BLOCAGE DEFINITIF DU SYSTÈME D'ENROULEUR .

2 SACHETS



4 RILSAN



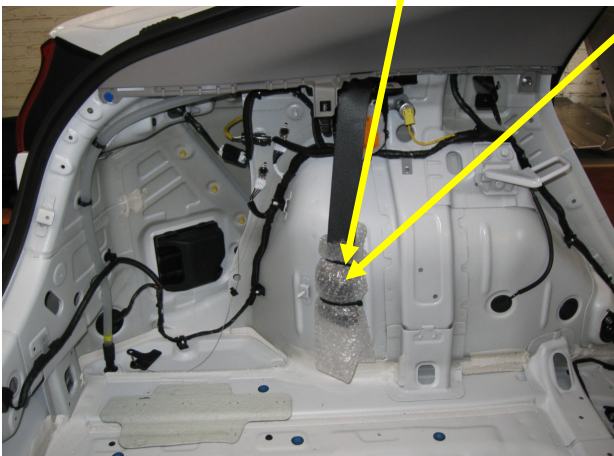

d) Démonter les garnitures latérales et conditionner les ceintures



KIT SOCIETE ARRET DE CHARGE

5) Monter la structure dans l'ordre suivant:

a) Positionner les pièces REF S0800 et les fixer avec les 2 vis d'origine du véhicule + 2 vis REF PLOVP6X16 + 2 x   S0807



VIS ORIGINE VEHICULE

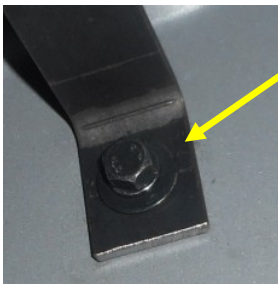

b) Positionner l'équerre de finition REF T00799 et la serrer .

2 x REF PLOVP6X16

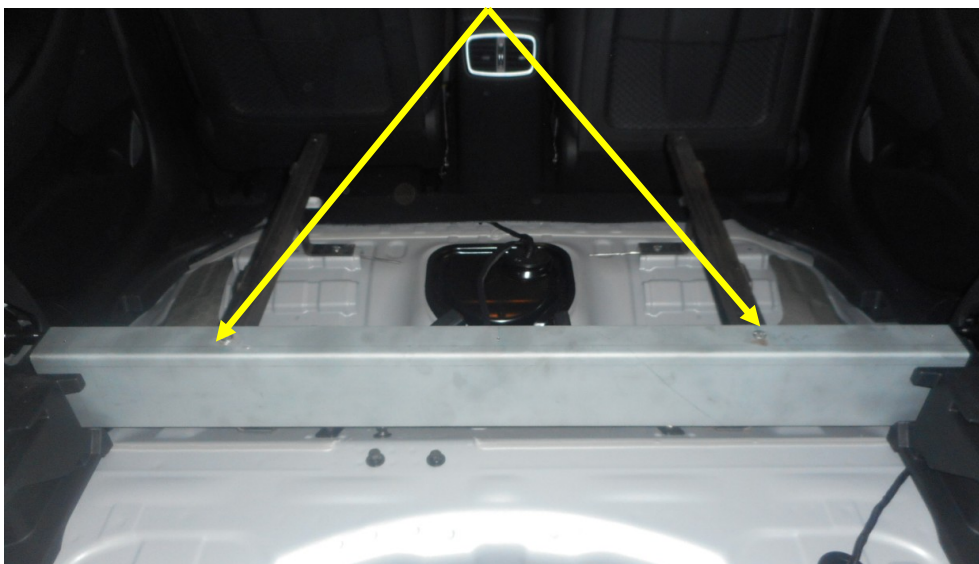
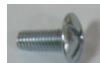

c) Monter les cornières latérales ref T00780 et la cornières av ref T00801 avec les vis REF PLO616N + PLOCL.

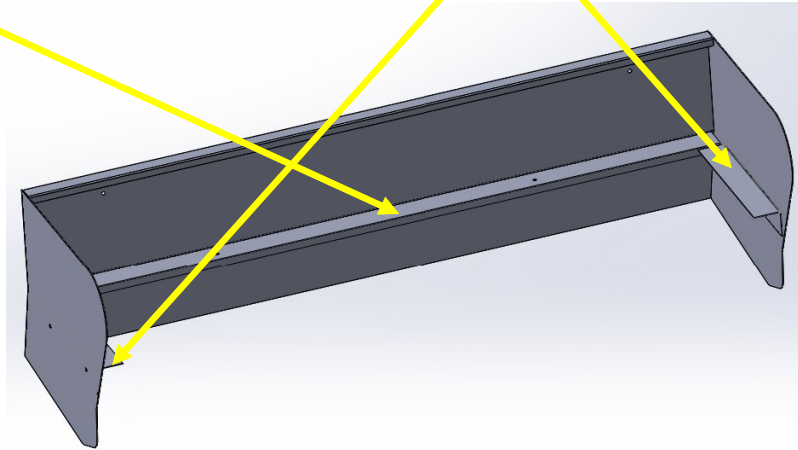
7 x 7 x 

d) Positionner et fixer l'ensemble dans le véhicule .

2 x REF PLOVP6X40

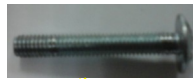

2 x REF PLOCL6

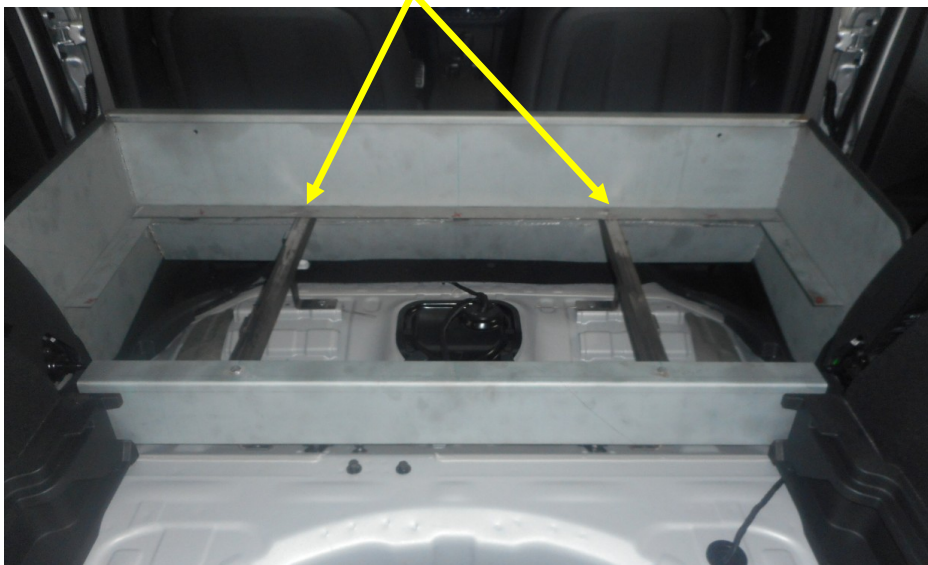

e) Fixer les 2 bouchons obturateurs REF NIORET 1234 .



2 x



f) Positionner et fixer le plancher .

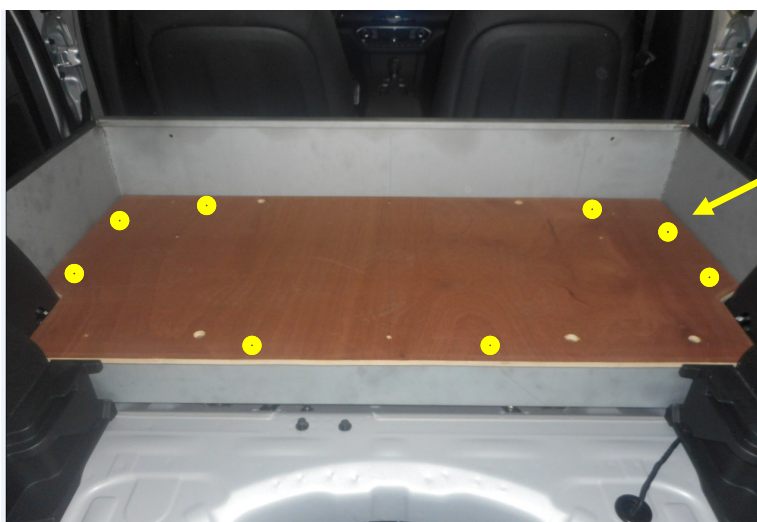

8 x 

8 VIS AUTOPERFO REF FOR 925

g) Repositionner le plancher d'origi-



h) Positionner la moquette .



i) Fixer les anneaux d'arrimage .

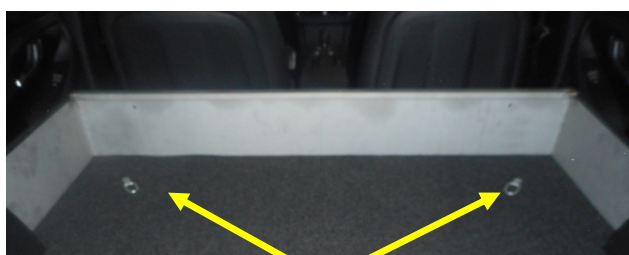

2 x REF POM825 + 2 x REF

j) Découper la moquette pour utilisation si besoin des anneaux d'amarrage d'origine .



5) Coller la plaque de transformation :

Depuis le 1er Juillet 2015 , date d'entrée en vigueur de l'arrêté du 7 Novembre 2014 , il n'y a plus ni plaque de tare ni plaque de chargement a apposer sur un véhicule transformé en VASP

LA PLAQUE AUTOCOLLANTE EST EXPEDIEE AVEC LE KIT .

(DANS LE SACHET DE VISSERIE)

COLLER LA PLAQUE DE TRANSFORMATION A PROXIMITE DE LA PLAQUE CONSTRUCTEUR.

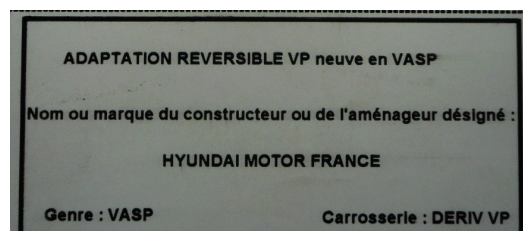

6) Nettoyer le véhicule.



| | |
|--------------------------|--|
| MARQUE DU VEHICULE : | |
| TYPE DU VEHICULE : | |
| N° de CLEF du VEHICULE : | |

IFAB111

INDICE A

| | OPERATION | Conforme | Non conforme | OBSERVATIONS |
|----|---|----------|--------------|--------------|
| | | C | NC | |
| 1 | RECEPTION DU VEHICULE VERIFIER N° SERIE | C | NC | |
| 2 | CONTRÔLE DU KIT | C | NC | |
| 3 | PRESENCE NOTICE MONTAGE | C | NC | |
| 4 | DEMONTAGE des EQUIPEMENTS SELON MODE OPERATEUR | C | NC | |
| 5 | PREPARATION DE L'HABITACLE Ex : vis pastilles joints | C | NC | |
| 6 | MONTAGE STRUCTURE METALLIQUE ARRET DE CHARGE | C | NC | |
| 7 | FIXATION DU PLANCHER SELON COUPLE DE SERRAGE | C | NC | |
| 8 | POSE DE LA MOQUETTE VERIFIER L'ETAT | C | NC | |
| 9 | INSTALLATION ELEMENTS FINITION Vérifier : caches, carres de moquette, anneau | C | NC | |
| 10 | POSE DE L'ETIQUETTE VASP | C | NC | |
| 11 | NETTOYAGE DU VEHICULE | C | NC | |

| | |
|--------------------------|--|
| NOM DU MONTEUR : | |
| DATE DE L'INTERVENTION : | |
| SIGNATURE DU MONTEUR : | |

| |
|------------------------------------|
| CACHET DU CARROSSIER / GARAGISTE : |
| |

