

M.A.J Le :
Indice de modif :
Nom dessinateur :







TOYOTA C-HR HYBRIDE 122 CH – 184 CH GRILLE ARRET DE CHARGE NOTICE DE MONTAGE



COMPOSITION DU COLIS

REF	DESIGNATION	QTE
TO2147	GRILLE TOLE PERFOREE	1
F2146	PLATINE DE FIXATION	2
TO2145	PATTE DE FIXATION	1D/1G
S2149	SACHET DE VISSERIES	1

Composition du sachet de visserie

REF ARTICLE	DESIGNATION	QTE	PHOTO
PLOVP6X16N	VIS POELIER 6 X 16 N	4	
FOR 0736	ECROU TENSILOCK M6	4	
PLOVP6X25N	VIS POELIER 6 X 25 NOIR	2	
BOU6271	BOUTON CEVENNE M6	2	

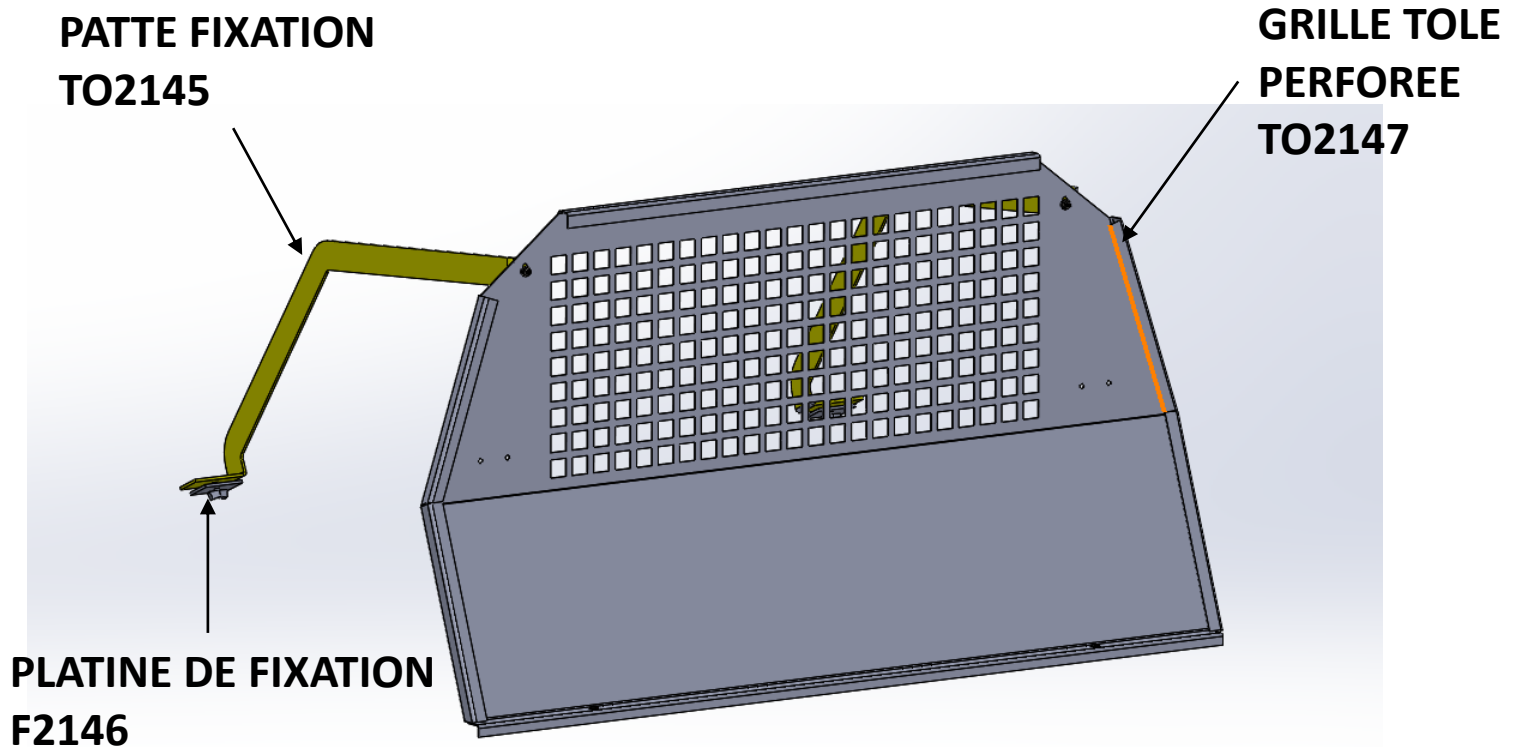

- 1) Réceptionner le véhicule et vérifier le N° de série.
Placer le véhicule sur une aire de travail propre et stable
- 2) Contrôler le kit
- 3) Lire la notice de montage

4) Fixer la grille sur l'arrêt de charges a l'aide de 2 vis poêlier et 2 écrous tensilock

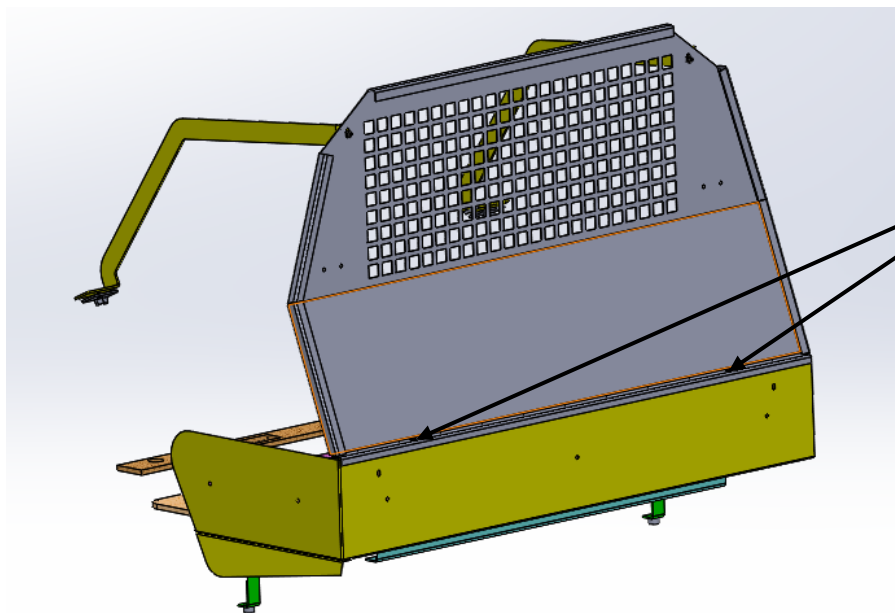

REF PLOVP6X16N
Qté : 2



REF FOR 0736
Qté : 2

5) Fixer les pattes de fixation grille TO2145 sur la grille

Fixer la grille et la patte de fixation a l'aide de 1 vis POELIER M6X16 avec 1 écrou Tensilock M6

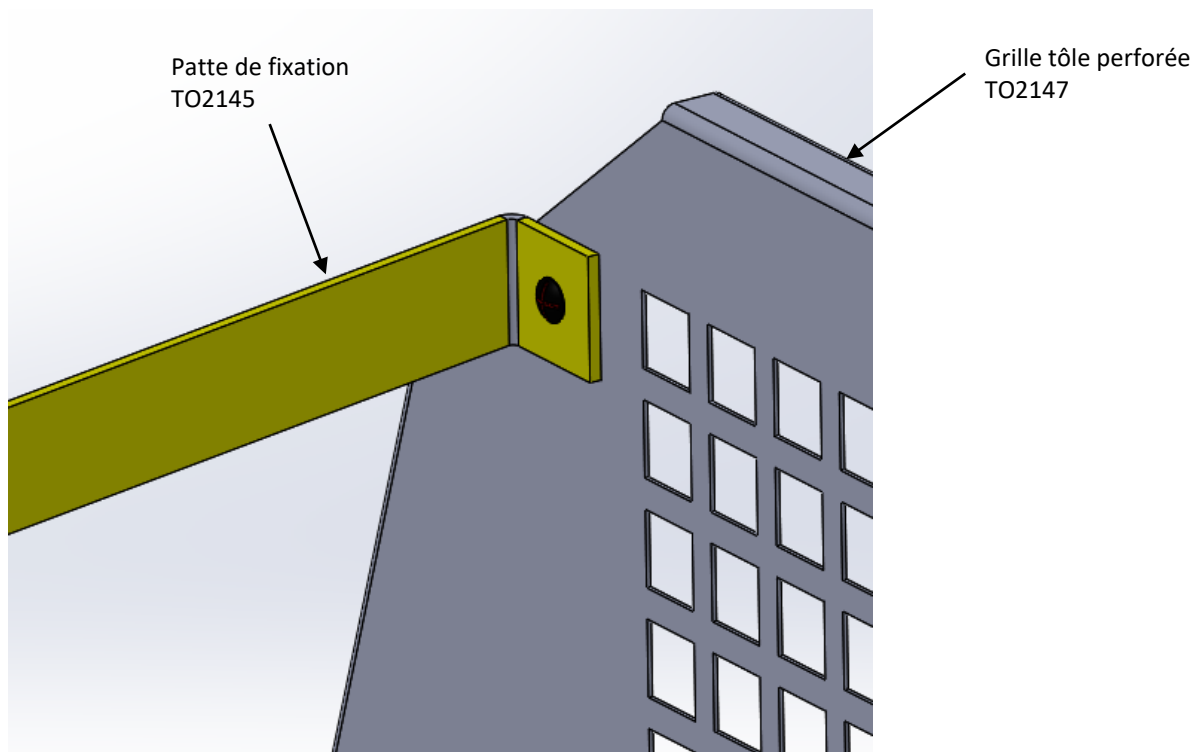

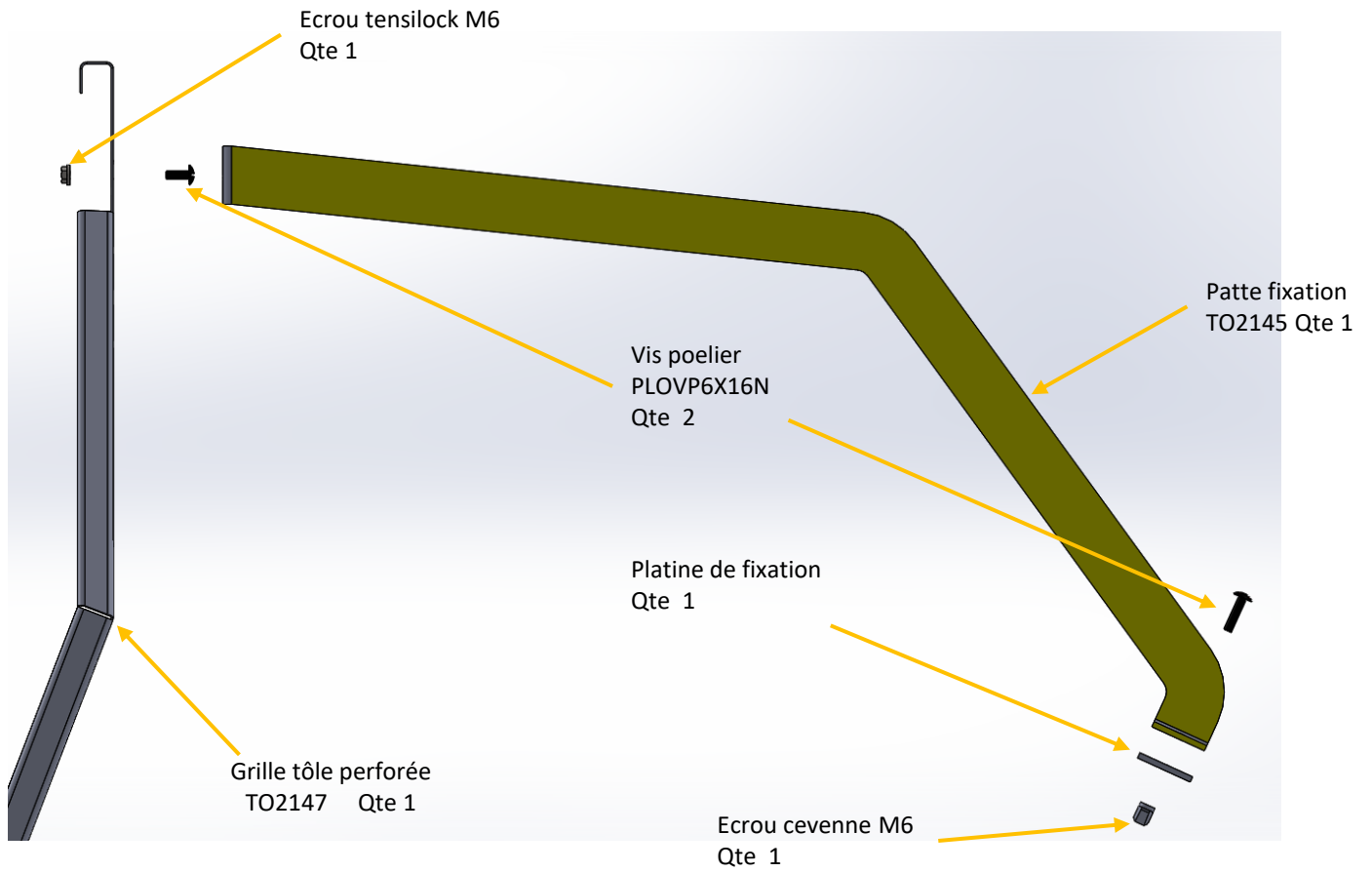

Visser la grille dans les fixations existant

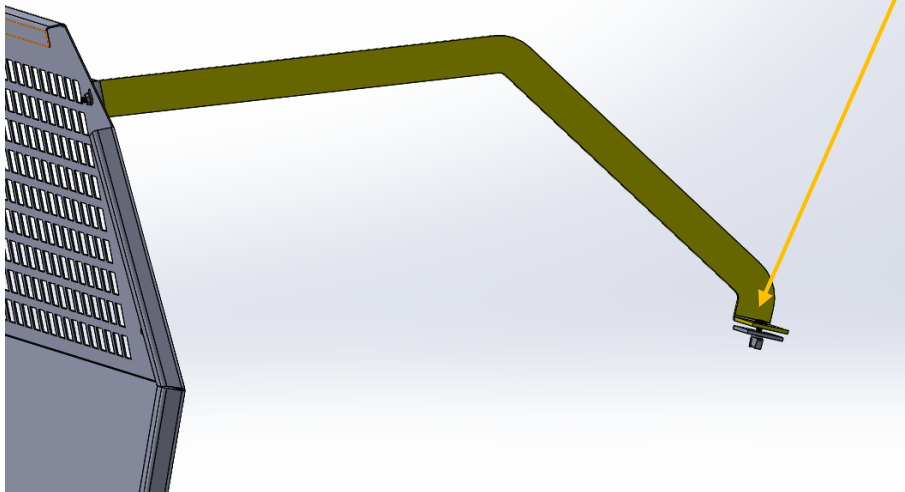

6) Nettoyer le véhicule