

M.A.J Le : 28/05/2020  
Indice de modif : Création  
Nom dessinateur : JR



# TOYOTA C-HR HYBRIDE 184 CH KIT SOCIETE NOTICE DE MONTAGE



## COMPOSITION DU COLIS

REF	DESIGNATION	QTE
S0822	ENVELOPPE ARRET DE CHARGE	1
TO0826	TRAVERSE AVANT	2
TO0825	TRAVERSE ARRIERE	1
TO0823	PATTE FIXATION SUPPORT ARRIERE	2
TO3009	EQUERRE LATERALE PLANCHER	2
TO3010	EQUERRE TRANSVERSALE PLANCHER	1
TO3011	RENFORT MILIEU PLANCHER	1
B3012	PLANCHER AVANT	1
B3013	PLANCHER ARRIERE	1
M3015	MOQUETTE	1
V3016	SACHET DE VISSERIES	1
N3014	NOTICE DE MONTAGE	1

Composition du sachet de visserie

REF ARTICLE	DESIGNATION	QTE	PHOTO
PLOVP616 Z	VIS POELIER 6 X 16 Z	4	
PLOCL6	ECROU TENSILOCK M6	9	
TU0836	ENTRETOISE	2	
PLOVH8X30	VIS TETE HEXA 8X30	2	
REF 1803	CARRE MOQUETTE AUTOCOLLANTE 150X150	2	
PLOMU8	RONDELLE PLATE M8	4	
PLOVH8X20	VIS TETE HEXA 8X20	2	
PLOT8	RONDELLE TOLIER M8	2	
PLOCL8	ECROU TENSILOCK 8	2	
PLOVP616 N	VIS POELIER 6 X 16 N	7	
PLOVH6X20	VIS TETE HEXA 6X20	8	
PLOMU6	RONDELLE PLATE M6	8	
PLOVTF6X20	Vis tête fraiser 6 x 20	3	
FOR 925	vis autoforante Ø3,9 x 25	8	
FOR971	AGRAFE M6	8	
ANNEAU ARRIMAGE	ACIER GALVA	2	
FOR 285	RILSAN	2	
SACHET	SACHET PLASTIQUE	2	
	Plaque autocollante de Transformation VASP	1	

# KIT SOCIETE ARRET DE CHARGES

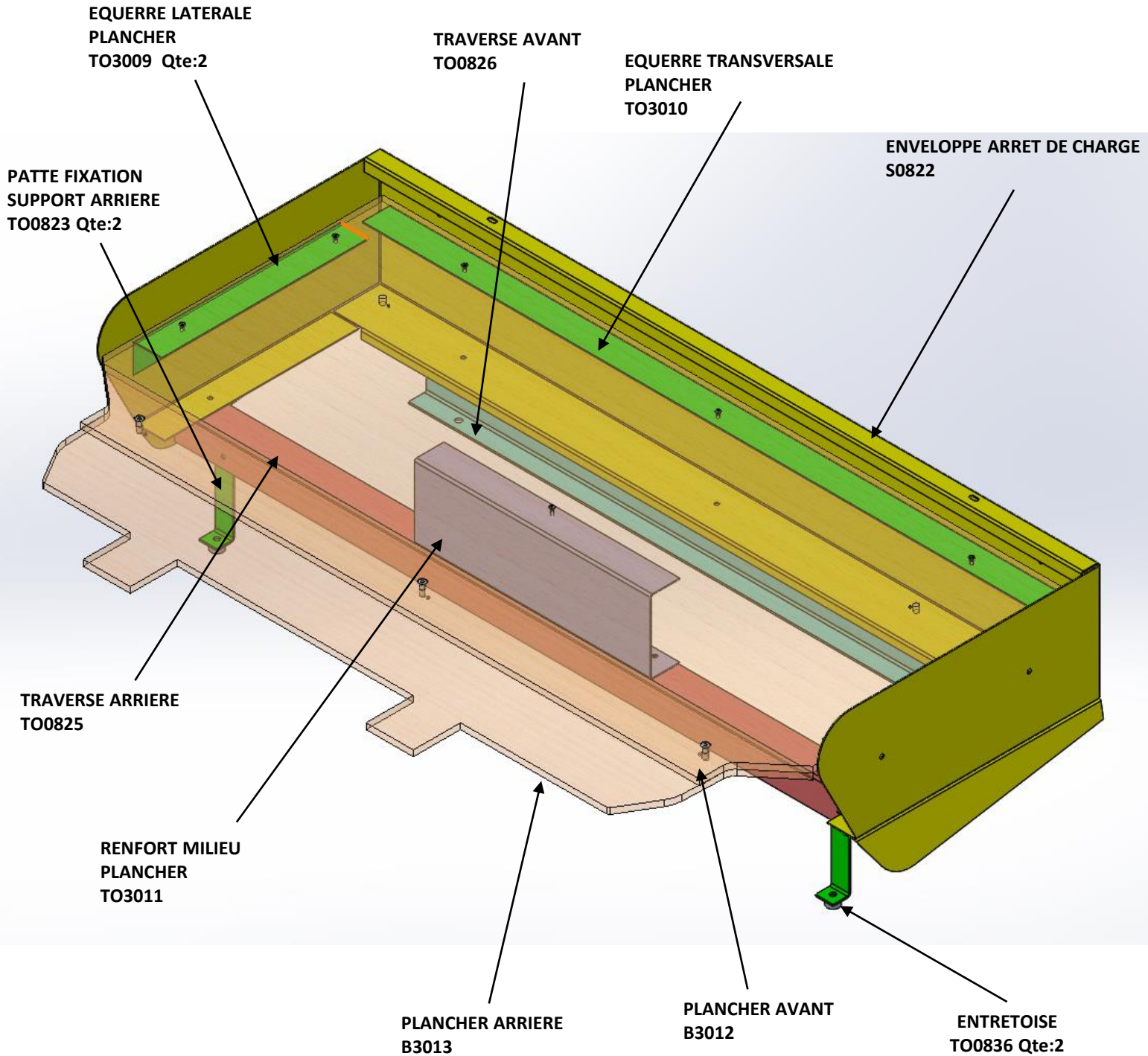



## KIT SOCIETE ARRET DE CHARGES

- 1) Réceptionner le véhicule et vérifier le N° de série.  
Placer le véhicule sur une aire de travail propre et stable
- 2) Contrôler le kit
- 3) Lire la notice de montage téléchargé sur le site [jocquin.com](http://jocquin.com)

### ATTENTION :

LA BATTERIE DU VEHICULE DOIT IMPERATIVEMENT ETRE DEBRANCHEE  
PENDANT LA DUREE DE L'INTERVENTION

- 4) Démontez les équipements dans l'ordre suivant :

- a) Démontez la banquette arrière  
et les dossiers



## KIT SOCIETE ARRET DE CHARGES

### b) Démonter les garnitures latérales



SACHET  
PLASTIQUE  
QTE : 2

### c) Conditionner les ceintures de sécurités



CARRE  
MOQUETTE  
QTE : 2

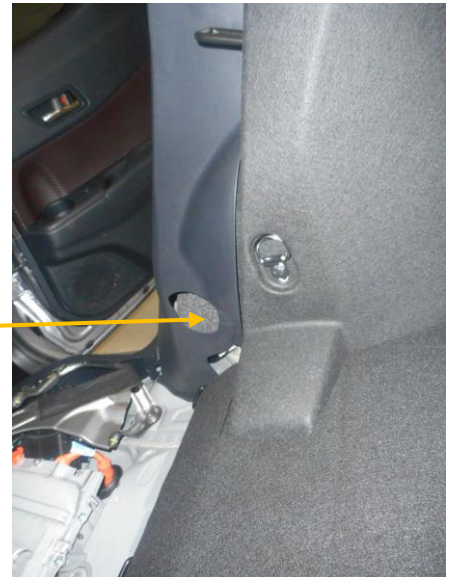

### d) Repositionner les garnitures

#### ATTENTION :

**DANS TOUS LES CAS, POUR LE CONDITIONNEMENT DES CEINTURES IL EST IMPERATIF DE LAISSER 50 cm DE GARDE POUR EVITER LE BLOCAGE DEFINITIF DU SYSTEME D'ENROULEUR.**

**L' HABITACLE DOIT ETRE DANS CETTE CONFIGURATION  
POUR MONTER L' ARRET DE CHARGES**





## KIT SOCIETE ARRET DE CHARGES

### 5) Mise en place des équerres latérales et transversales TO3009 et TO3010 sur l'arrêt de charges S0822

Arrêt de charges  
S0822

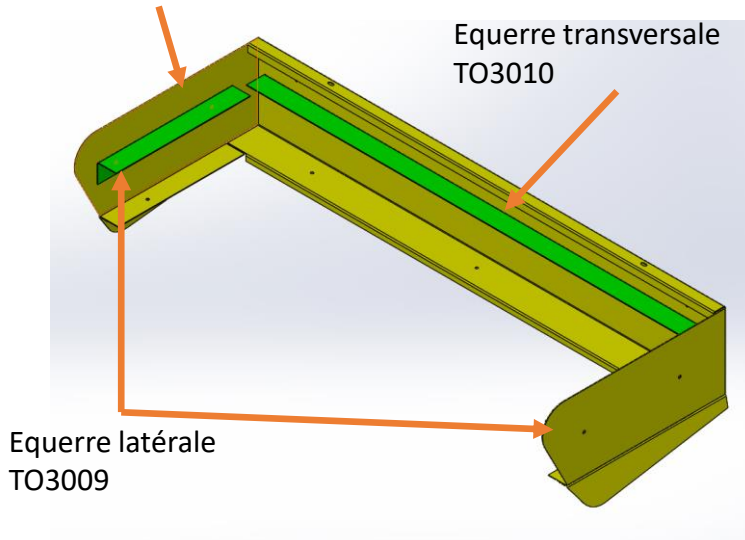

Ceci a l'aide de 7 Vis poêliers M6x16  
et 7 écrous tansilock M6



REF PLOVP616 N  
Qté : 7



REF PLOCL6  
Qté : 7

### 6) Fixer les agrafes sur la traverse arrière TO0825 et avant TO0826



REF FOR 791  
Qté : 5

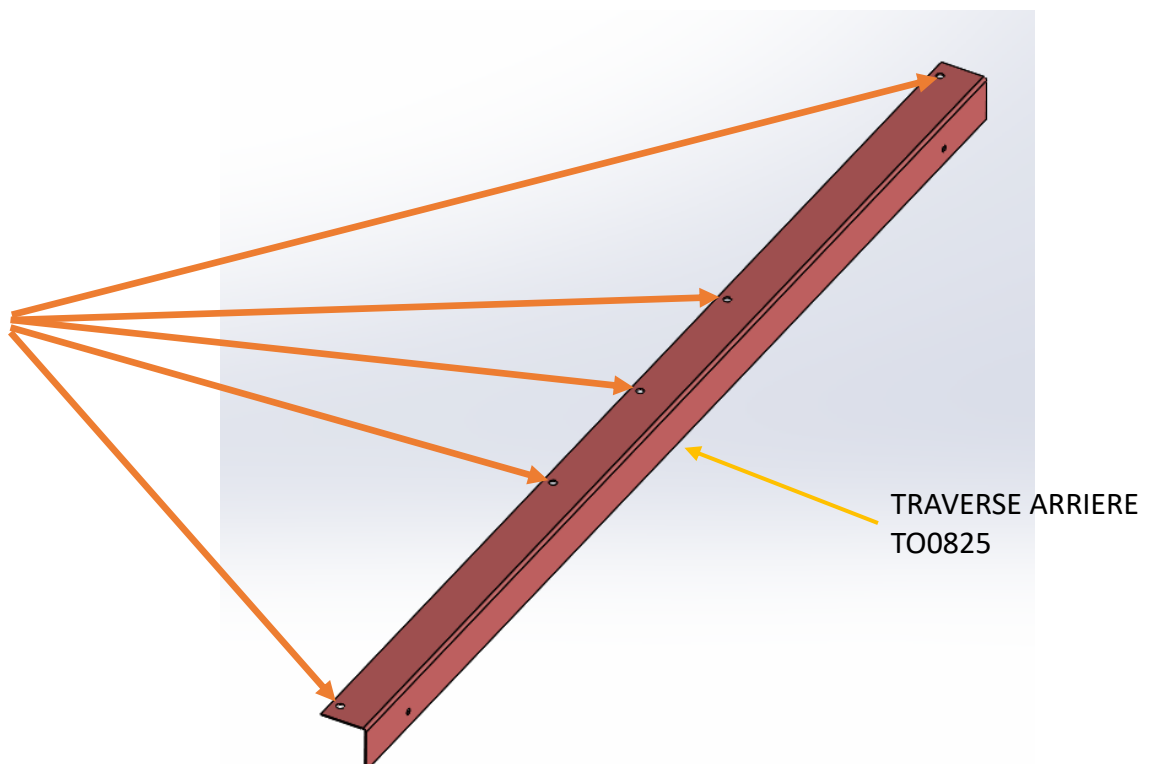



## KIT SOCIETE ARRET DE CHARGES

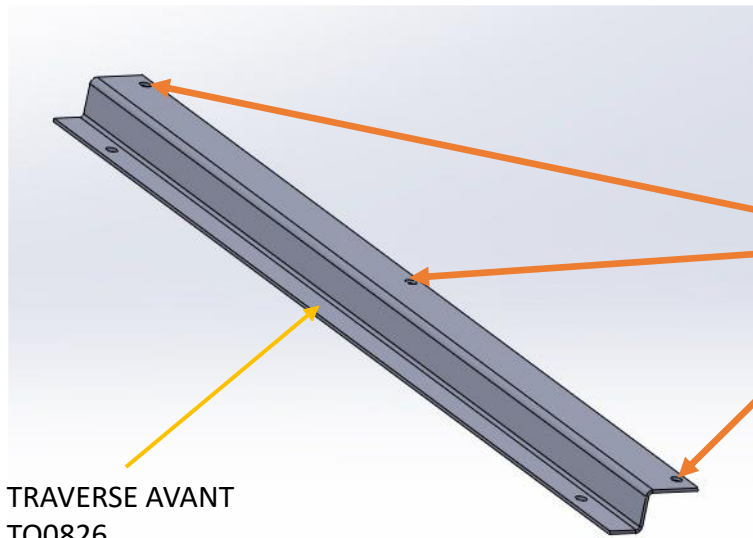

TRAVERSE AVANT  
TO0826



REF FOR 791  
Qté : 3

### 7) Fixer la traverse avant TO0826

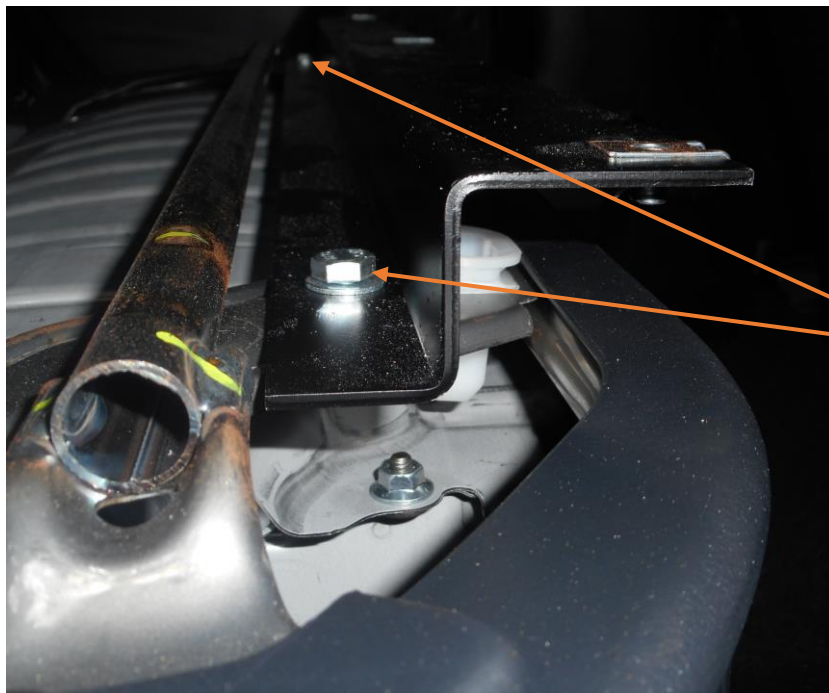

Vis hexa 8X20  
PLOVH8X20  
Qté : 2



Rondelle  
PLOMU8  
Qté : 2



Rondelle Tolier  
PLOT8  
Qté : 2



Erou tensilock 8  
PLOCL8  
Qté : 2

## KIT SOCIETE ARRET DE CHARGES

### 8) Fixer les pattes fixation support arrière TO0823

Positionner les entretoises TU0836 puis visser les pattes TO0823



### 9) Fixer la traverse arrière TU0828

Vis Poelier  
PLOVP 6X16 Z  
Qté : 2

Ecrou tensilock 6  
PLOCL6  
Qté : 2

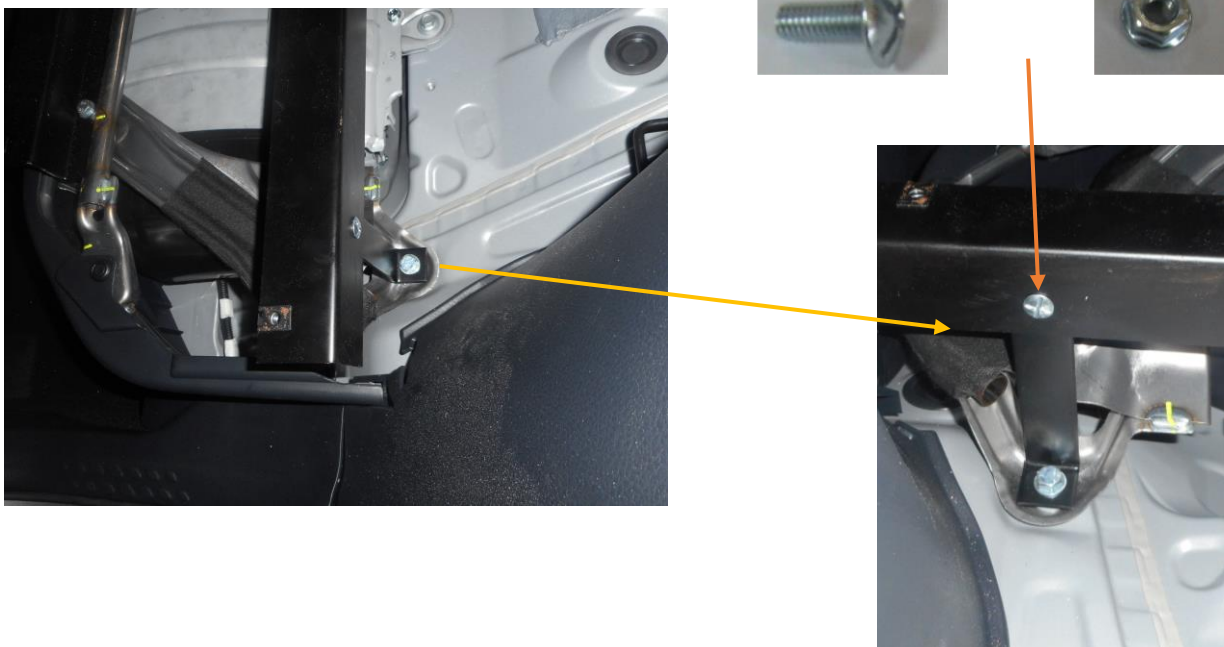

## KIT SOCIETE ARRET DE CHARGES

**10 )** Fixer le renfort plancher milieu TO3011 sur la traverse arrière TO0825



Vis hexa 6X20  
PLOVH6X20  
Qté : 3



Rondelle  
PLOMU6  
Qté : 3

**11)** Fixer l'arrêt de charge sur les traverses avant et arrière

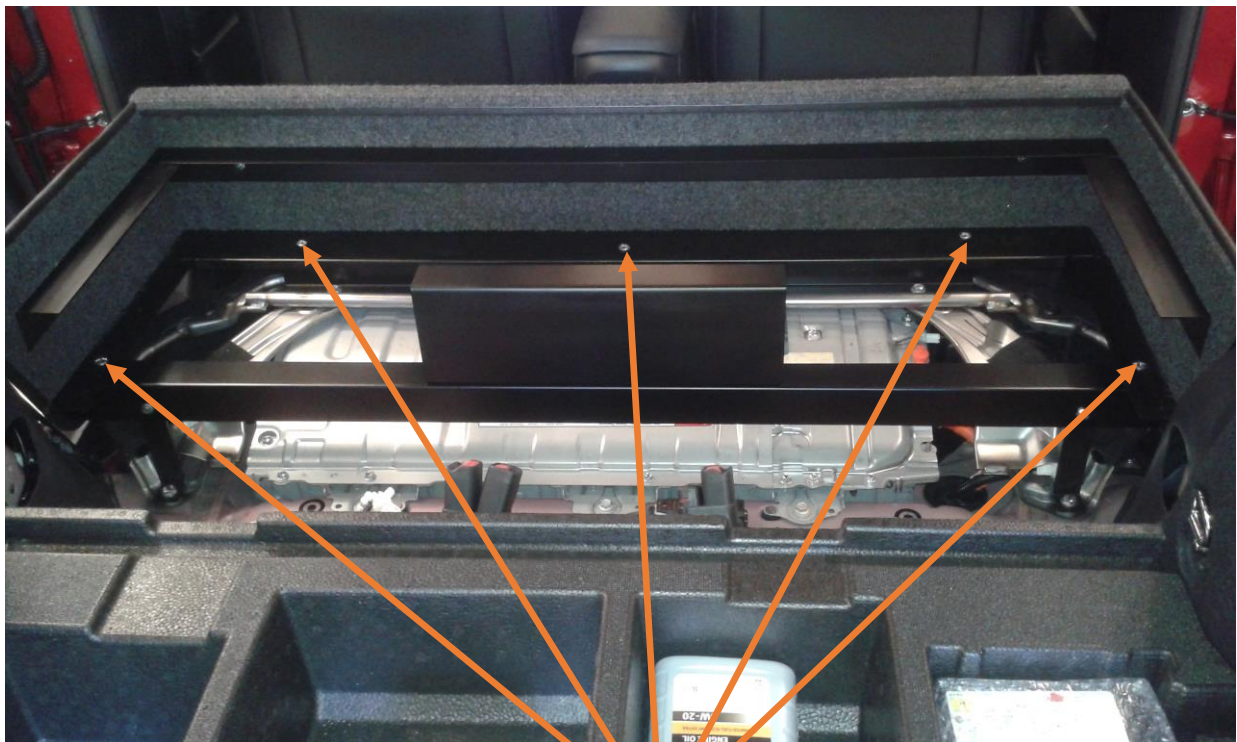

Vis hexa 6X20  
PLOVH6X20  
Qté : 5



Rondelle  
PLOMU6  
Qté : 5



## KIT SOCIETE ARRET DE CHARGES

### 12) Assembler les deux partie du plancher

Visser les deux partie du plancher à l'aide de 3 vis tête fraiser 6 x 20 qui viendront se fixer dans les inserts



Vis fraiser 6 x 20  
PLOVTF6X20  
Qté : 3

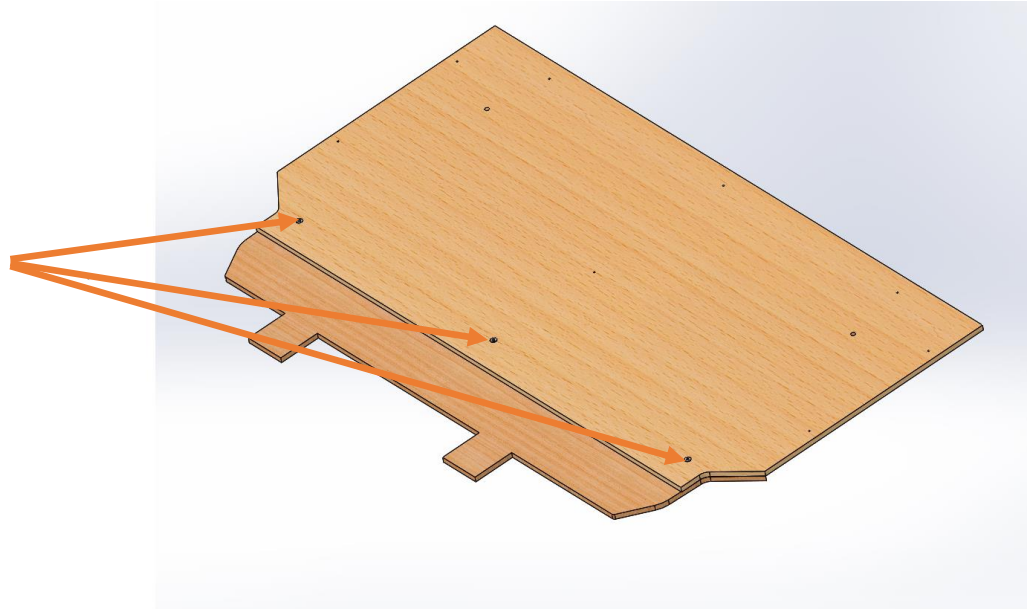

### 13) Fixer le plancher sur l'arrêt de charge

Fixer le plancher à l'aide de 8 vis autoforante  $\varnothing 3,9$  x 25



Vis autoforante  
FOR 925  
Qté : 8





## KIT SOCIETE ARRET DE CHARGES

### 11 ) Mise en place du plancher existant puis de la moquette M3015



Plancher existant

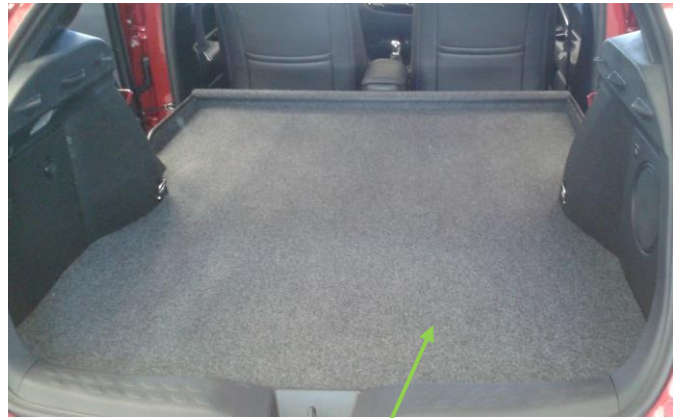

Moquette M3015

### 14) Mise en place de 2 anneaux d'arrimage

Fixation des 2 anneaux d'arrimage  
avec 2 vis poêlier M6x16



REF PLOVP 616 Z  
Qté : 2



Anneaux d'arrimage  
Qté : 2

## KIT SOCIETE ARRET DE CHARGES

### 13 ) Coller la plaque de transformation :

Depuis le 1<sup>er</sup> Juillet 2015, date d'entrée en vigueur de l'arrêté du 7 Novembre 2014, il n'y a plus ni plaque de tare ni plaque de chargement à apposer sur un véhicule transformé en VASP

**LA PLAQUE AUTOCOLLANTE EST EXPEDIEE AVEC LE KIT.  
(DANS LE SACHET DE VISSERIE)**

COLLER LA PLAQUE DE TRANSFORMATION A PROXIMITE DE LA PLAQUE CONSTRUCTEUR

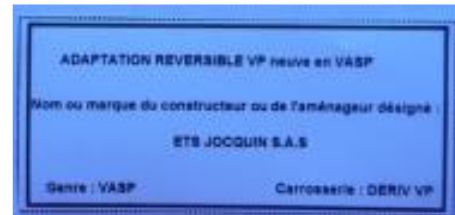

### 14 ) Nettoyer le véhicule



MARQUE DU VEHICULE :	
TYPE DU VEHICULE :	
N° de CLEF du VEHICULE :	

IFAB111  
INDICE A

	OPERATION	Conforme C	Non conforme NC	OBSERVATIONS
1	RECEPTION DU VEHICULE VERIFIER N° SERIE	C	NC	
2	CONTRÔLE DU KIT	C	NC	
3	PRESENCE NOTICE MONTAGE	C	NC	
4	DEMONTAGE des EQUIPEMENTS SELON MODE OPERATEUR	C	NC	
5	PREPARATION DE L'HABITACLE Ex : vis pastilles joints	C	NC	
6	MONTAGE STRUCTURE METALLIQUE ARRET DE CHARGE	C	NC	
7	FIXATION DU PLANCHER SELON COUPLE DE SERRAGE	C	NC	
8	POSE DE LA MOQUETTE VERIFIER L'ETAT	C	NC	
9	INSTALLATION ELEMENTS FINITION Vérifier : caches, carres de moquette, anneau arrimage	C	NC	
10	POSE DE L'ETIQUETTE VASP	C	NC	
11	NETTOYAGE DU VEHICULE	C	NC	

NOM DU MONTEUR :	
DATE DE L'INTERVENTION :	
SIGNATURE DU MONTEUR :	

CACHET DU CARROSSIER / GARAGISTE :

## KIT SOCIETE ARRET DE CHARGES

**ATTENTION** : Les cotes de chargement sont données  
Sans les banquettes arrières

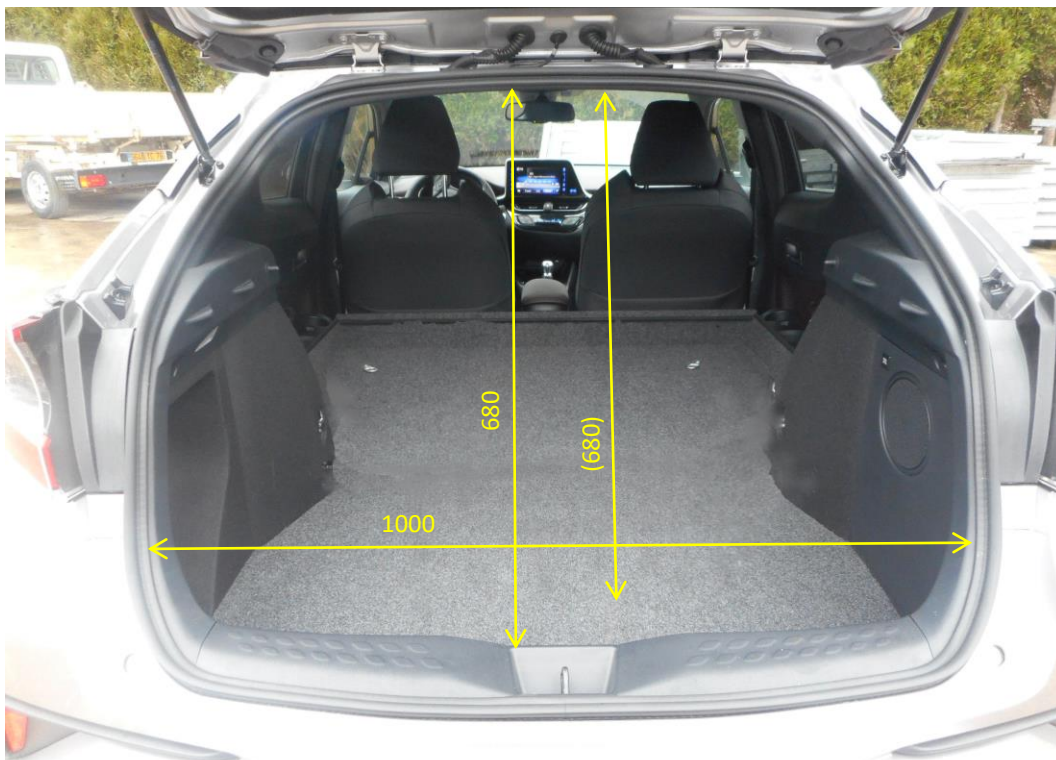
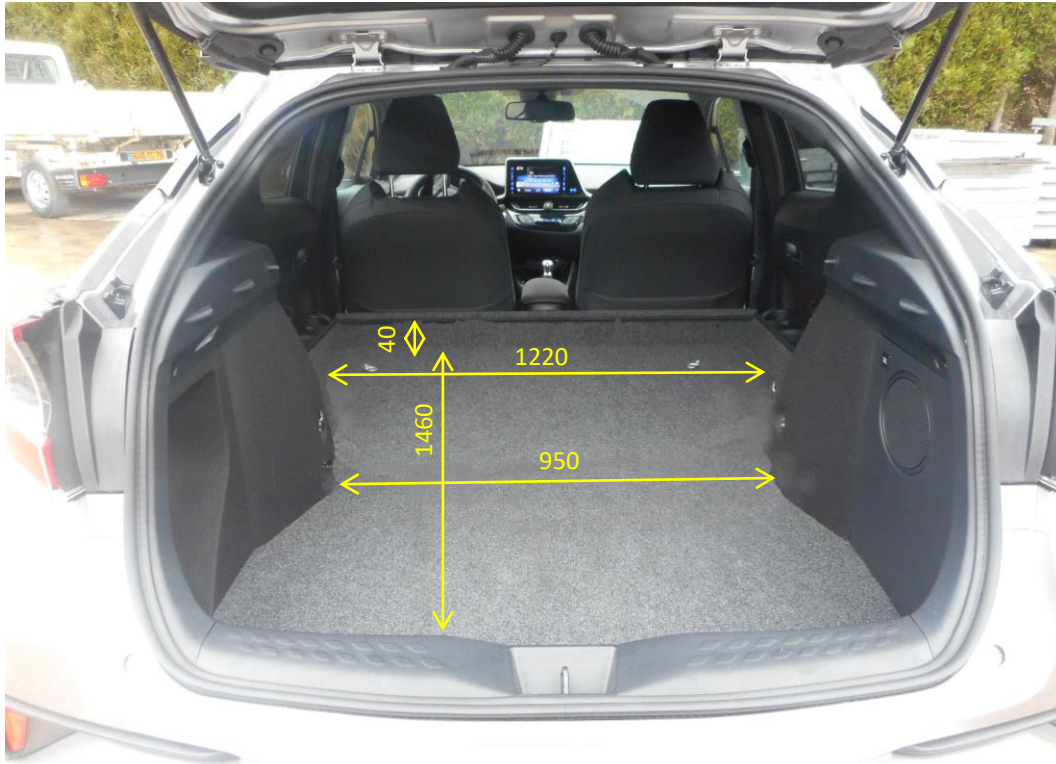

( 870 ) hauteur intérieure plancher / plafond

Masse ensemble banquette : 22 Kg

Masse ensemble Kit société : 23 Kg