

M.A.J Le : 12/03/2024
Indice de modif : Ind B
Nom dessinateur : JR



**SUZUKI VITARA APK
5 PORTES 2015
KIT SOCIETE
NOTICE DE MONTAGE**











COMPOSITION DU COLIS

REF	DESIGNATION	QTE
TO0181	ENVELOPPE ARRET DE CHARGES	1
TO0183	TRAVERSE ARRIERE	1
TO0184	TRAVERSE CENTRALE	1
TO0185	LONGERON DROITE ET GAUCHE	1D/1G
TO0084*	PLATINE SUPPORT TRAPPE	2
B0187	PLANCHER PARTIE AVANT	1
B0188	PLANCHER PARTIE ARRIERE	1
B0189	PLANCHER TRAPPE ROUE DE SECOURS	1
M0201	MOQUETTE FINITION PLANCHER	1
V0200	SACHET DE VISSERIES	1

Réf TO0084 mis dans le sachet visseries

Composition du sachet de visserie

REF ARTICLE	DESIGNATION	QTE	PHOTO
PLOVP616 Z	VIS POELIER 6x16 Z	8	
PLOVP625 Z	VIS POELIER 6x25 Z	4	
PLOVH616	VIS HEXAGONALE 6x16	8	
PLOVTF630	VIS TETE FRAISEE 6x30	8	
PLOCL6	ECROU TENSILOCK M6	12	
PLOMU6	RONDELLES PLATE Ø 6	8	
FOR925	Vis Autoforante 3,9 x 25	3	
CHARNIERE PLASTISQUE	CHARNIERE PLASTIQUE	2	
FOR 295	VIS CHARNIERE 4,2 X 9,5	8	
FOR791	Ecrou (cage) M6	8	
ANNEAU ARRIMAGE	ACIER GALVA	4	
DEC7320	RIVET 4,8 X 20	4	
TO0084	PLATINE SUPPORT TRAPPE	2	
FOR200	RILSAN	8	
SACHET PLASTIQUE	SACHET PLASTIQUE	6	
	Plaque autocollante de Transformation VASP	1	

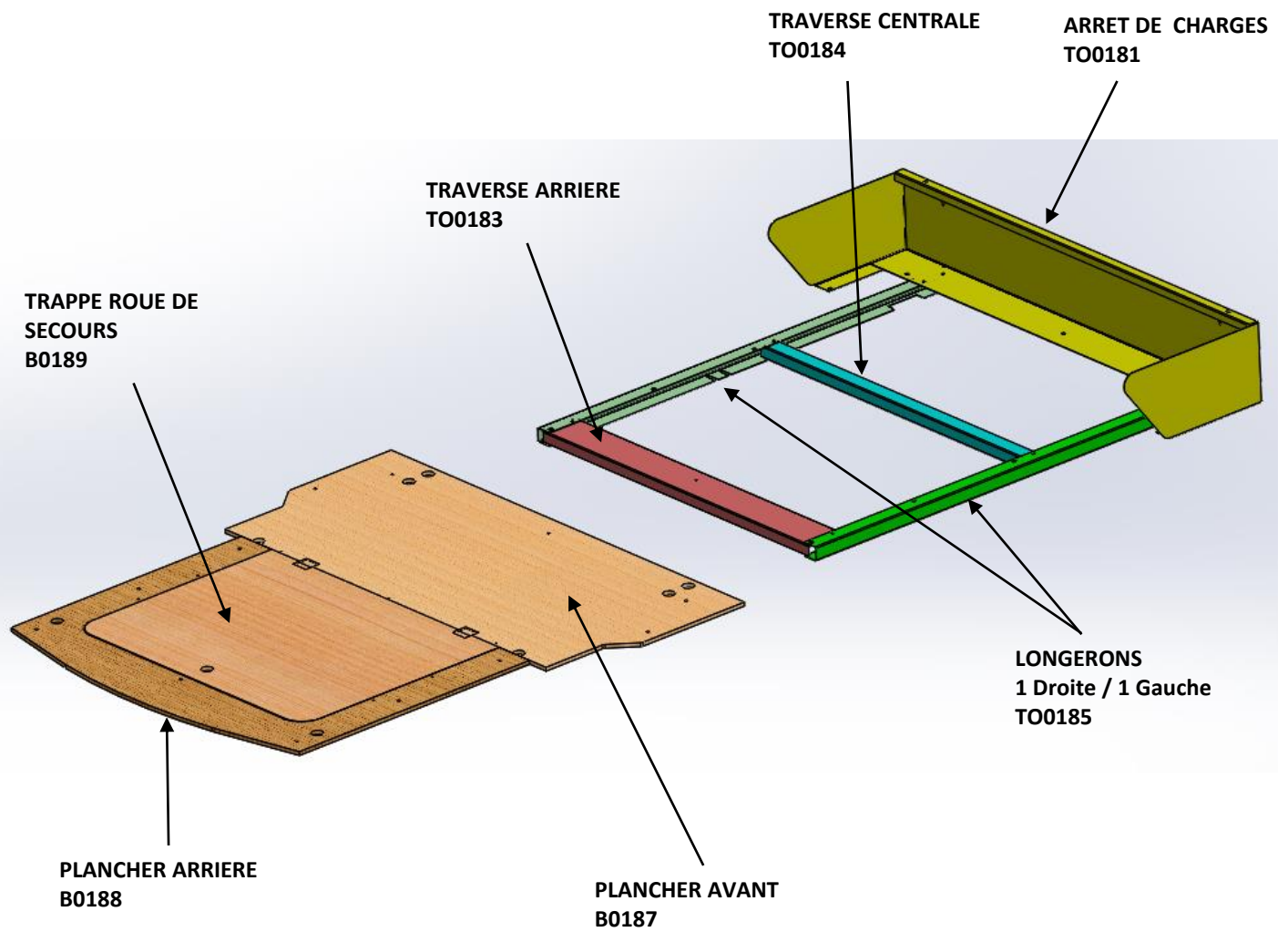

1) Réceptionner le véhicule et vérifier le N° de série .

Placer le véhicule sur une aire de travail propre et stable.

2) Contrôler le kit .

3) Lire la notice de montage.

LA BATTERIE DU VEHICULE DOIT ETRE DEBRANCHEE PENDANT LA DUREE DE L'INTERVENTION.

4) Démontez les équipements dans l'ordre suivant.

a) Démontez la plage arrière



b) Enlever le plancher du coffre



c) Démontez les caches des assises



d) Démontez les assises



e) Dévisser les fixations des attaches .

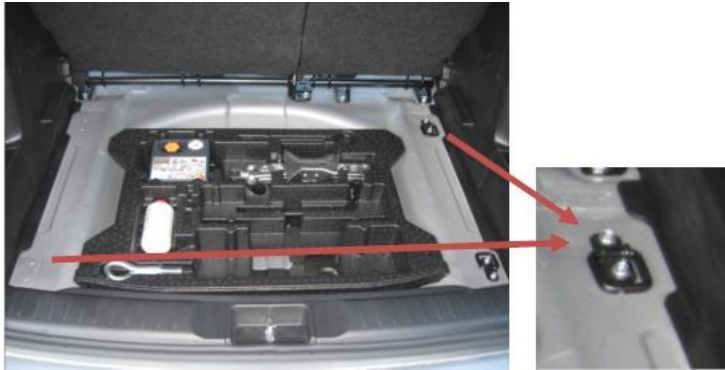

f) Dévisser les fixations a l' arriere des dossiers .



g) Dévisser les fixations a l'avant des dossiers .



h) Conditionner les ceintures .

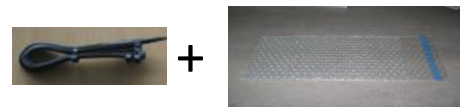

i) Démontez les garnitures .



j) Conditionner les ceintures .

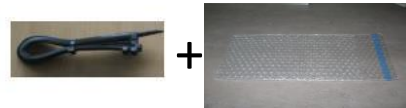

k) Démontez les attaches uniquement si
Le véhicule n'est pas équipé d'un couvre
bagages .



**ATTENTION POUR LE CONDITIONNEMENT DES CEINTURES IL EST IMPERATIF DE LAISSER ENVIRON
50 cm DE GARDE POUR EVITER LE BLOCAGE DEFINITIF DU SYSTEME D'ENROULEUR.**

L) Démontez les garnitures du pavillon pour conditionner la ceinture .

(sachet plastique + collier rilsan)

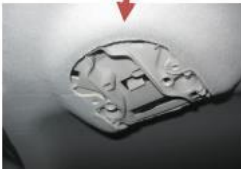
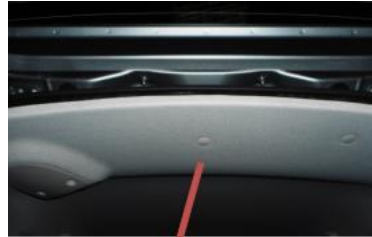

Cache a enlever



Cache a enlever



+



m) Remonter les garnitures .



**L' HABITACLE DOIT ETRE DANS CETTE CONFIGURATION POUR
MONTER L' ARRET DE CHARGES**



5) Mise en place des écrous cage sur les longerons T00185 et sur l'arrêt de charges T00181

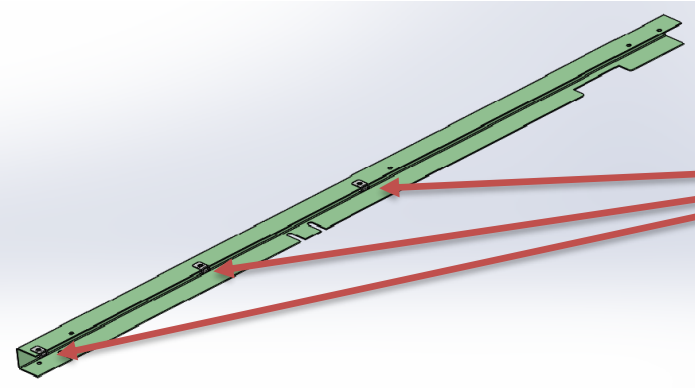

REF FOR971
Qté : 6

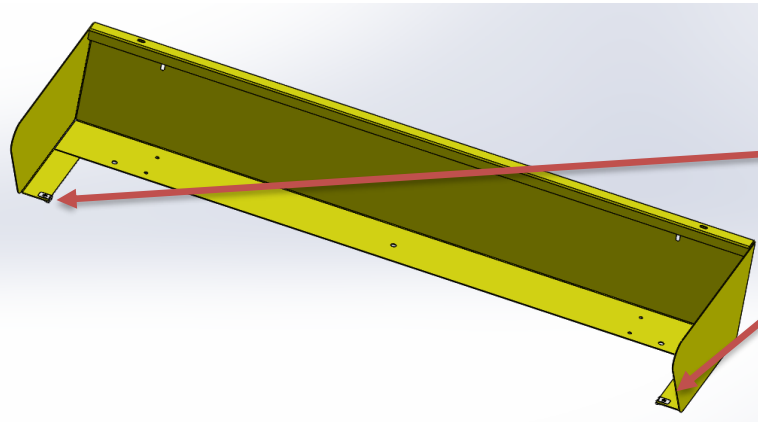

REF FOR971
Qté : 2

6) Fixation des 2 longerons T00185 avec les vis d'origine du véhicule ou avec les vis fournies Réf PLOVH6 x 16 et rondelles plate Ø 6

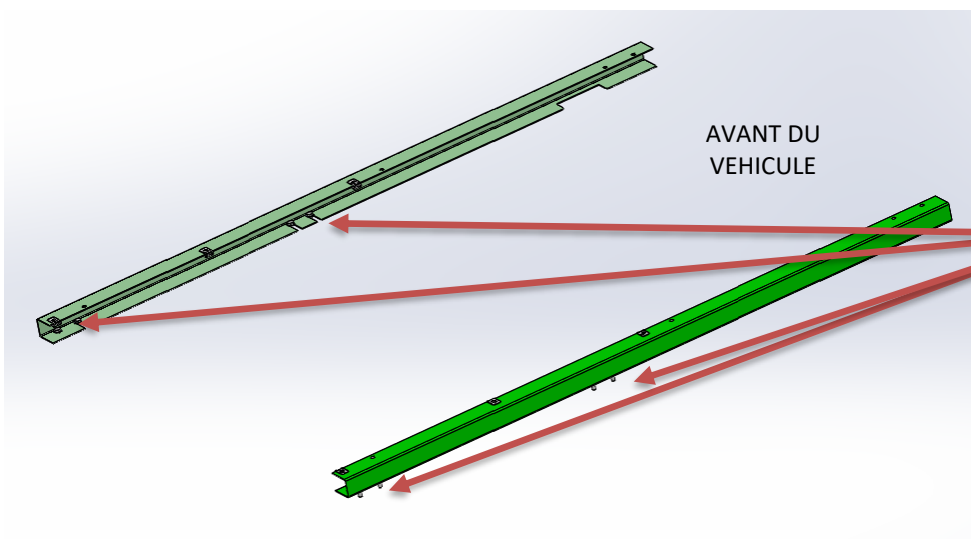

REF PLOVH6 x 16
Qté : 8



REF PLOMU6
Qté : 8

7) Fixation de la traverse centrale Réf TO0184

Ceci à l'aide de 2 vis poêlier M6 x 16 et 2 écrous tensilock M6

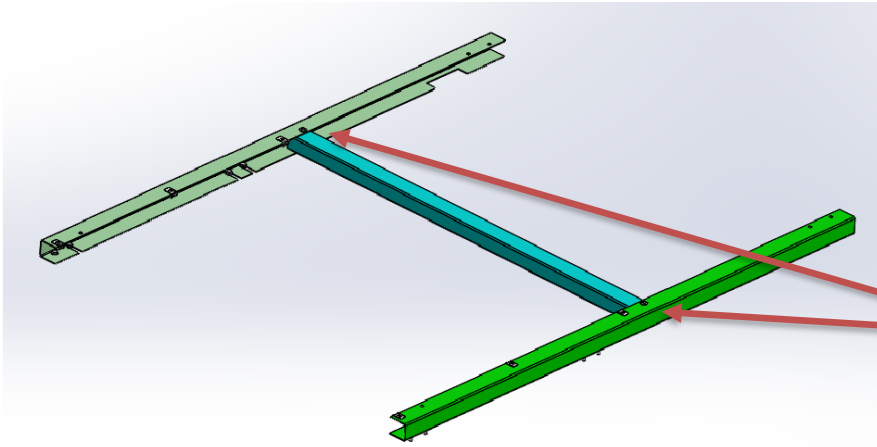

REF PLOVP616Z
Qté : 2



REF PLOCL6
Qté : 2

8) Fixation de la traverse arrière Réf TO0183

Ceci à l'aide de 2 vis poêlier M6 x 16 et 2 écrous tensilock M6

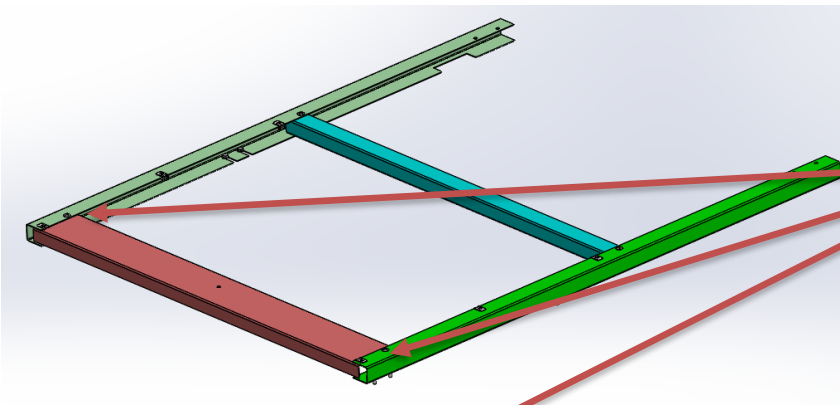

REF PLOVP616Z
Qté : 2



REF PLOCL6
Qté : 2

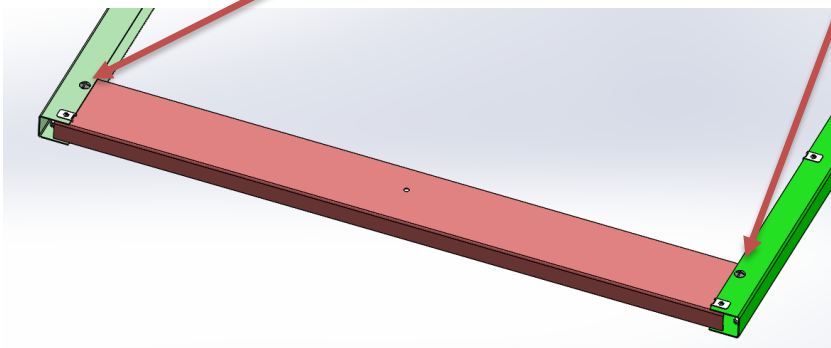

9) Fixation de l'arrêt de charges Réf TO0181

Ceci à l'aide de 4 vis poêlier M6 x 16 et 4 écrous tensilock M6

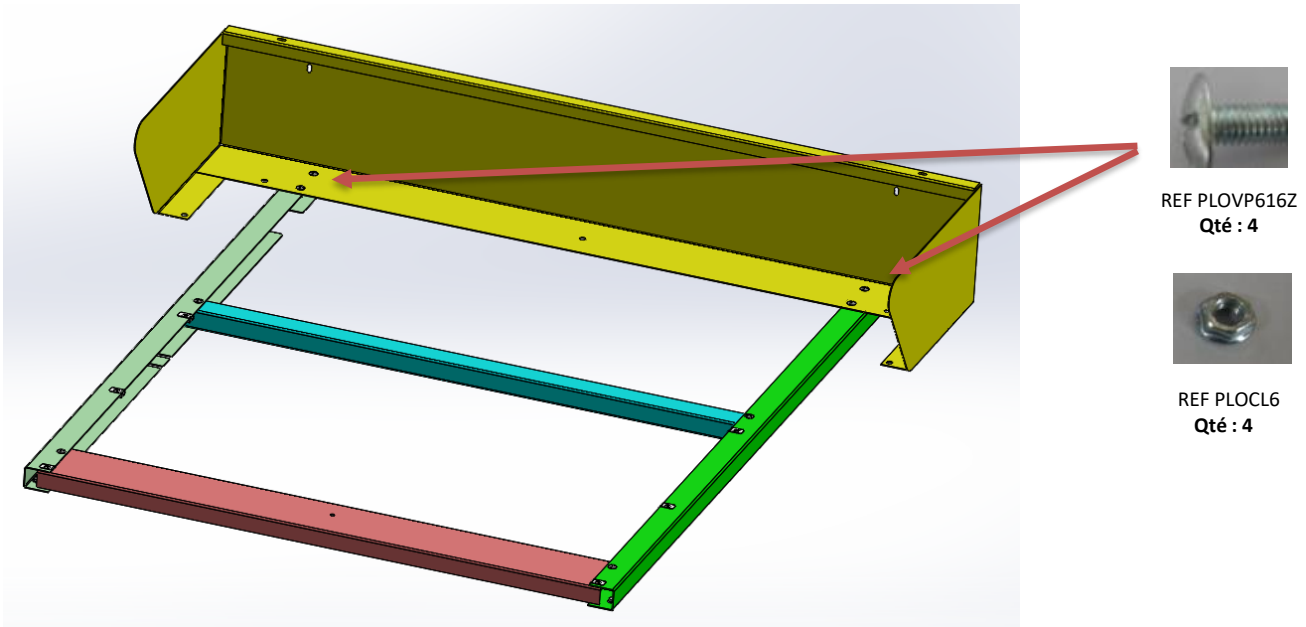

10) Mise en place des platines support trappe Réf TO0084 Sous le plancher arrière réf B0188

Ceci à l'aide de 4 rivets 4,8 x 20

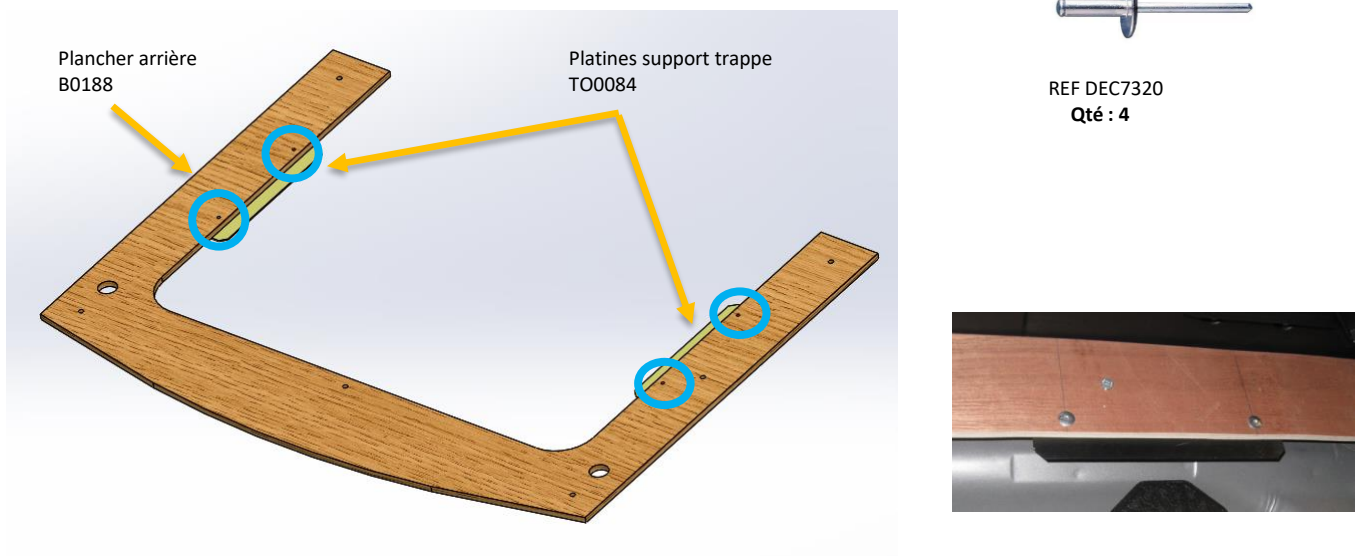

11) Fixation du plancher arrière B0188

Ceci à l'aide de 5 vis tête fraisées M6 x 30 et 1 écrou tensilock M6

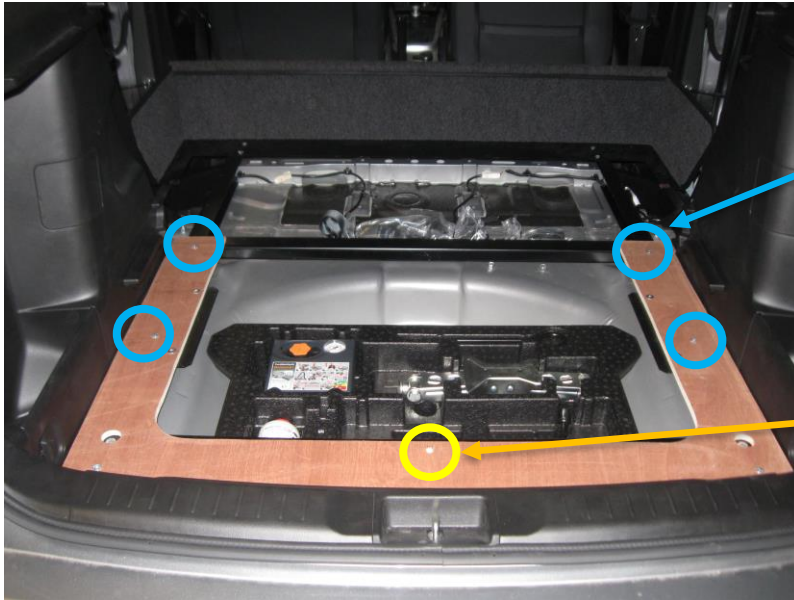

REF PLOVTF630
Qté : 4



REF PLOVTF630
Qté : 1



REF PLOCL6
Qté : 1

12) Fixation du plancher avant B0187

Ceci à l'aide de 3 vis tête fraisées M6 x 30 , 1 écrou tensilock M6 et 2 vis autoforante 3,9 x 25

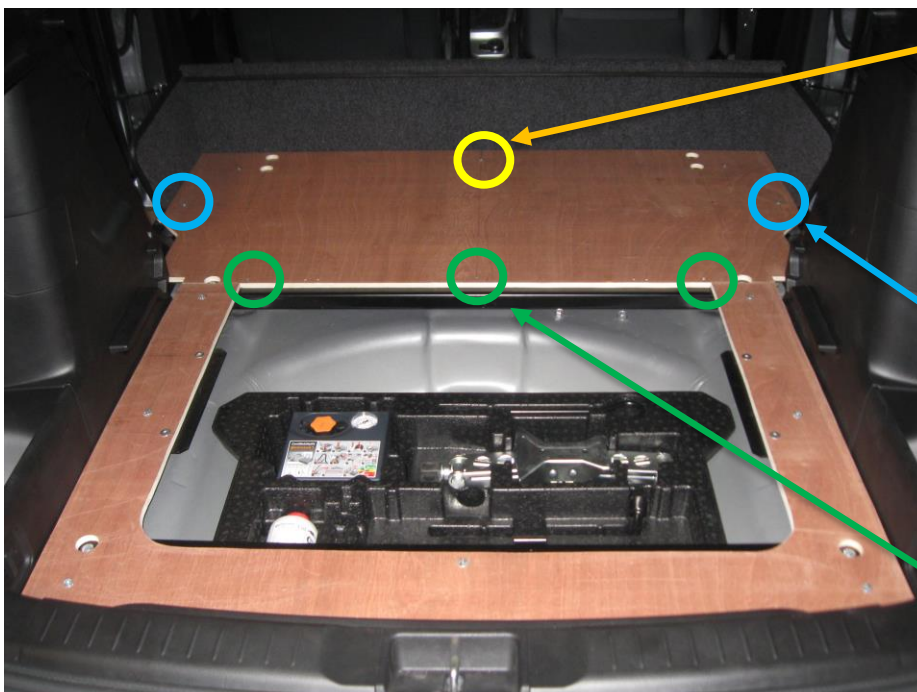

REF PLOVTF630
Qté : 1



REF PLOCL6
Qté : 1



REF PLOVTF630
Qté : 2



REF FOR925
Qté : 3

13) Mise en place de la trappe roue de secours B0189

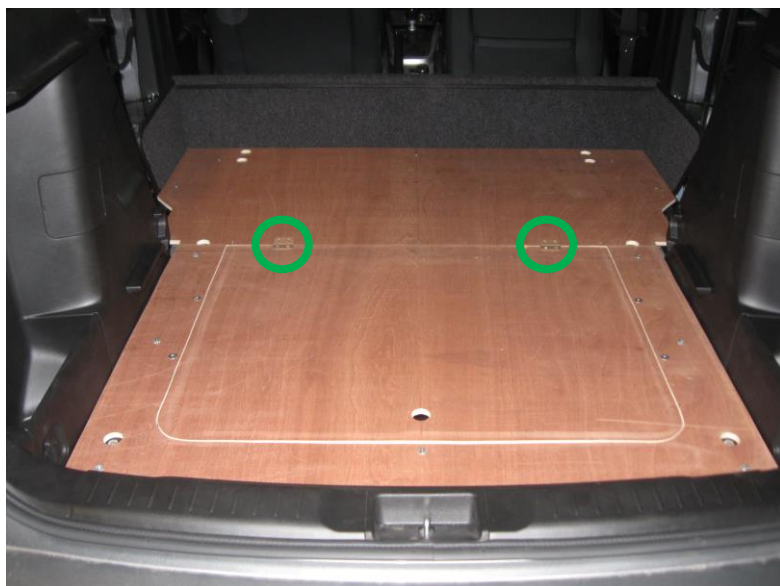

Venir mettre en place la trappe roue de secours et Venir fixer les charnières plancher



Vis charnière
Réf 4,2 x 9,5
QTE : 8



Charnière plancher
QTE : 2

14) Mise en place, à l'arrière, des 2 anneaux d'arrimage

Ceci à l'aide de 2 vis poêlier M6 x 25



Anneaux d'arrimage
Qté : 2

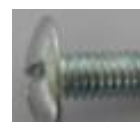

REF PLOVP 625 Z
Qté : 2

15) Mise en place de la moquette M0201



Mettre en place la moquette M0201 et découper celle-ci pour faire ressortir les 2 anneaux d'arrimage arrière

16) Mise en place des 2 anneaux d'arrimage de devant

Ceci à l'aide de 2 vis poêlier M6 x 25 et 2 écrous tensilock



Anneaux d'arrimage
Qté : 2



REF PLOVP 625 Z
Qté : 2



REF PLOCL6
Qté : 2

17) Coller la plaque de transformation

Depuis le 1^{er} Juillet 2015, date d'entrée en vigueur de l'arrêté du 7 Novembre 2014, il n'y a plus ni plaque de tare ni plaque de chargement a apposer sur un véhicule transformé en VASP

LA PLAQUE AUTOCOLLANTE EST EXPEDIEE AVEC LE KIT .

(DANS LE SACHET DE VISSERIE)

COLLER LA PLAQUE DE TRANSFORMATION A PROXIMITE DE LA PLAQUE CONSTRUCTEUR.

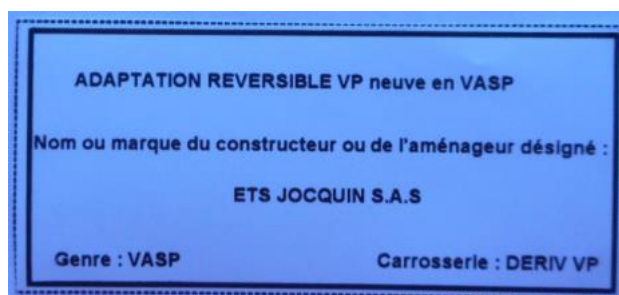

18) Nettoyer le véhicule



Masse ensemble banquette : 25 Kg
Masse ensemble Kit société : 19 Kg



MARQUE DU VEHICULE :	
TYPE DU VEHICULE :	
N° de CLEF du VEHICULE :	

	OPERATION	Conforme C	Non conforme NC	OBSERVATIONS
1	PRISE CONNAISSANCE DES CONSIGNES DE SECURITE	C	NC	
2	RECEPTION DE VEHICULE VERIFIER N° DE SERIE	C	NC	
3	CONTRÔLE DU KIT	C	NC	
4	PRESENCE NOTICE MONTAGE	C	NC	
5	DEMONTAGE DES EQUIPEMENTS SELON MODE OPERATEUR	C	NC	
6	PREPARATION DE L'HABITACLE Ex : vis pastilles joints	C	NC	
7	MONTAGE STRUCTURE METALLIQUE ARRET DE CHARGE	C	NC	
8	FIXATION DU PLANCHER SELON COUPLE DE SERRAGE	C	NC	
9	POSE DE LA MOQUETTE VERIFIER L'ETAT	C	NC	
10	INSTALLATION ELEMENTS FINITION Vérifier : caches, carres de moquette, anneau arrimage	C	NC	
11	POSE DE L'ETIQUETTE VASP	C	NC	
12	NETTOYAGE ET DESINFECTION DU VEHICULE	C	NC	

NOM DU MONTEUR :	
DATE DE L'INTERVENTION :	
SIGNATURE DU MONTEUR :	

CACHET DU CARROSSIER / GARAGISTE :