

M.A.J Le :  
Indice de modif :  
Nom dessinateur :

















# PEUGEOT 2008 KIT SOCIETE NOTICE DE MONTAGE



## COMPOSITION DU COLIS

REF	DESIGNATION	QTE
TO3080	ARRET DE CHARGES	1
TO3083	EQUERRE LATERALE	2
TO3084	EQUERRE TRANSVERSALE	1
TO3081	SUPPORT ARRET DE CHARGE	1D/1G
TO3082	SUPPORT CENTRAL	1
B3085	PLANCHER AVANT	1
B3086	PLANCHER ARRIERE	1
B3089	CALE PLANCHER	2
B3087	JONCTION PLANCHER AV-AR	1
B3088	TASSEAU RENFORT PLANCHER	1
M3090	MOQUETTE	1
S3092	SACHET DE VISSERIES	1
N3091	NOTICE DE MONTAGE	1

Composition du sachet de visserie

REF ARTICLE	DESIGNATION	QTE	PHOTO
PLOVP610 N	VIS POELIER 6 X 10 N	4	
PLOVP610 Z	VIS POELIER 6 X 10 Z	4	
PLOVP616 Z	VIS POELIER 6 X 16 Z	2	
PLOVTF6X20	VIS TETE FRAISE 6 X 20	3	
FOR 295	VIS CHARNIERE	4	
PLOCL6	ECROU TENSILOCK M6	8	
FOR 925	VIS Autoforante 3,9 x 25	21	
TOU620	TOURILLONS 6 X 20	4	
ANNEAU ARRIMAGE	ACIER GALVA	2	
CHARNIEREPLANCHER	CHARNIERE	2	
180 x 180	MOQUETTE AUTOCOLLANTE	2	
DEC 342	MOUSSE NOIR 15 x 5 Lg 100	2	
FOR 285	RILSAN	3	
SACHET	SACHET PLASTIQUE	3	
	Plaque autocollante de Transformation VASP	1	

# KIT SOCIETE ARRET DE CHARGES

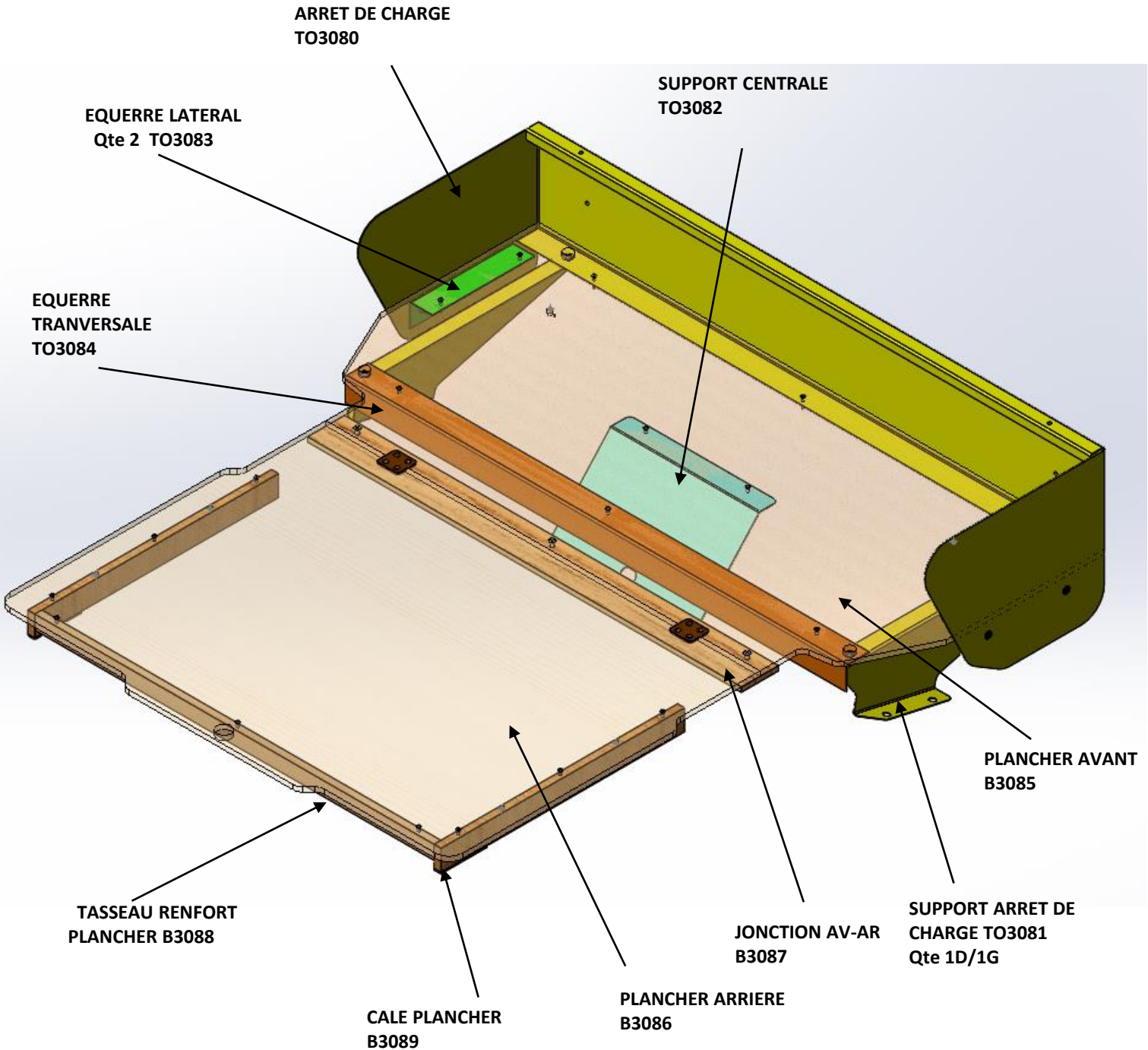

## KIT SOCIETE ARRET DE CHARGES

- 1) Réceptionner le véhicule et vérifier le N° de série.  
Placer le véhicule sur une aire de travail propre et stable
- 2) Contrôler le kit
- 3) Lire la notice de montage téléchargé sur le site [jocquin.com](http://jocquin.com)

### ATTENTION :

LA BATTERIE DU VEHICULE DOIT IMPERATIVEMENT ETRE DEBRANCHEE  
PENDANT LA DUREE DE L'INTERVENTION

- 4) Démontez les équipements dans l'ordre suivant :

- a) Démontez la banquette arrière  
et les dossiers



## KIT SOCIETE ARRET DE CHARGES

b) Démonter les garnitures latérales

c) Conditionner les ceintures de sécurités



SACHET  
PLASTIQUE  
QTE : 3



d) Repositionner les garnitures

Moquette autocollante



**ATTENTION :**

**DANS TOUS LES CAS, POUR LE CONDITIONNEMENT DES CEINTURES IL EST IMPERATIF DE LAISSER 50 cm DE GARDE POUR EVITER LE BLOCAGE DEFINITIF DU SYSTEME D'ENROULEUR.**

## KIT SOCIETE ARRET DE CHARGES

**L' HABITACLE DOIT ETRE DANS CETTE CONFIGURATION  
POUR MONTER L' ARRET DE CHARGES**

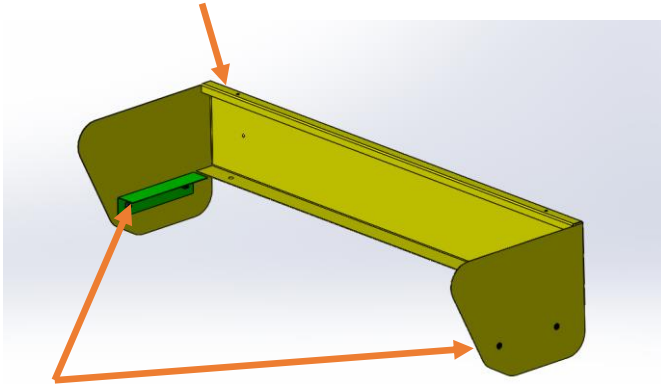

**KIT SOCIETE ARRET DE CHARGES****5) Mise en place des équerres latérale TO3083 sur l'arrêt de charges TO3080**Arrêt de charges  
TO3080Ceci a l'aide de 4 Vis poêliers M6  
et 4 écrous tansilock M6REF PLOVP610 N  
Qté : 4REF PLOCL6  
Qté : 4Equerre latérale  
TO3083**6) Mise en place des supports droite et gauche TO3081**

Fixer les support à l'aide des vis d'origine

Vis d'origine

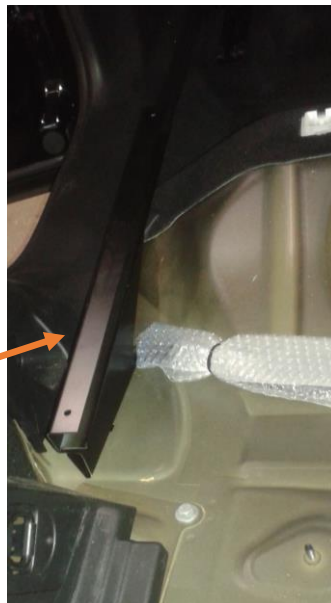



## KIT SOCIETE ARRET DE CHARGES

### 7) Mise en place de l'équerre transversale TO3084

Fixer l'équerre transversale a l'aide de 2 vis poêlier et 2 écrous tensilock



REF PLOVP610 Z  
Qté : 2



REF PLOCL6  
Qté : 2



Equerre  
transversale  
Réf TO3084

### 8) Mise en place de l'arrêt de charges TO3080

Visser l'arrêt de charge a l'aide de 2 vis poêlier et 2 écrous tensilock M6



REF PLOVP610 Z  
Qté : 2



REF PLOCL6  
Qté : 2

**KIT SOCIETE ARRET DE CHARGES****9) Mise en place du support central TO3082**

Vis d'origine

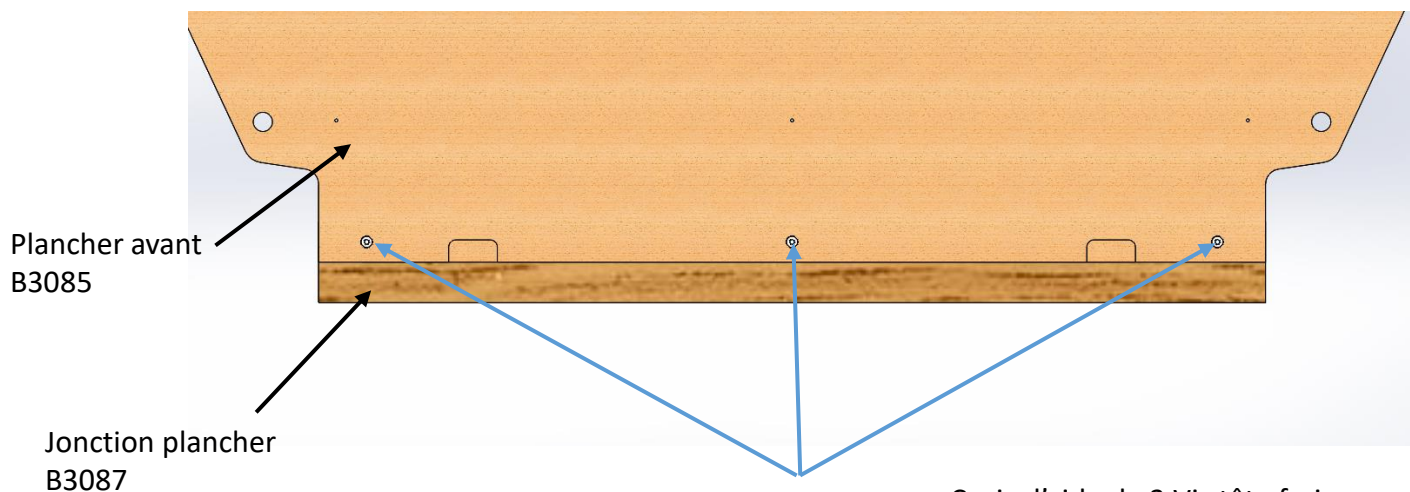
**10) Mise en place de la jonction plancher av-ar B3087 sur le plancher avant B3085**

Ceci a l'aide de 3 Vis tête fraise M6 x 20

REF PLOVTF6X20

Qté : 3

## KIT SOCIETE ARRET DE CHARGES

### 11) Mise en place des cales plancher B3089 et du tasseau renfort plancher B3088 sur le plancher arrière B3086

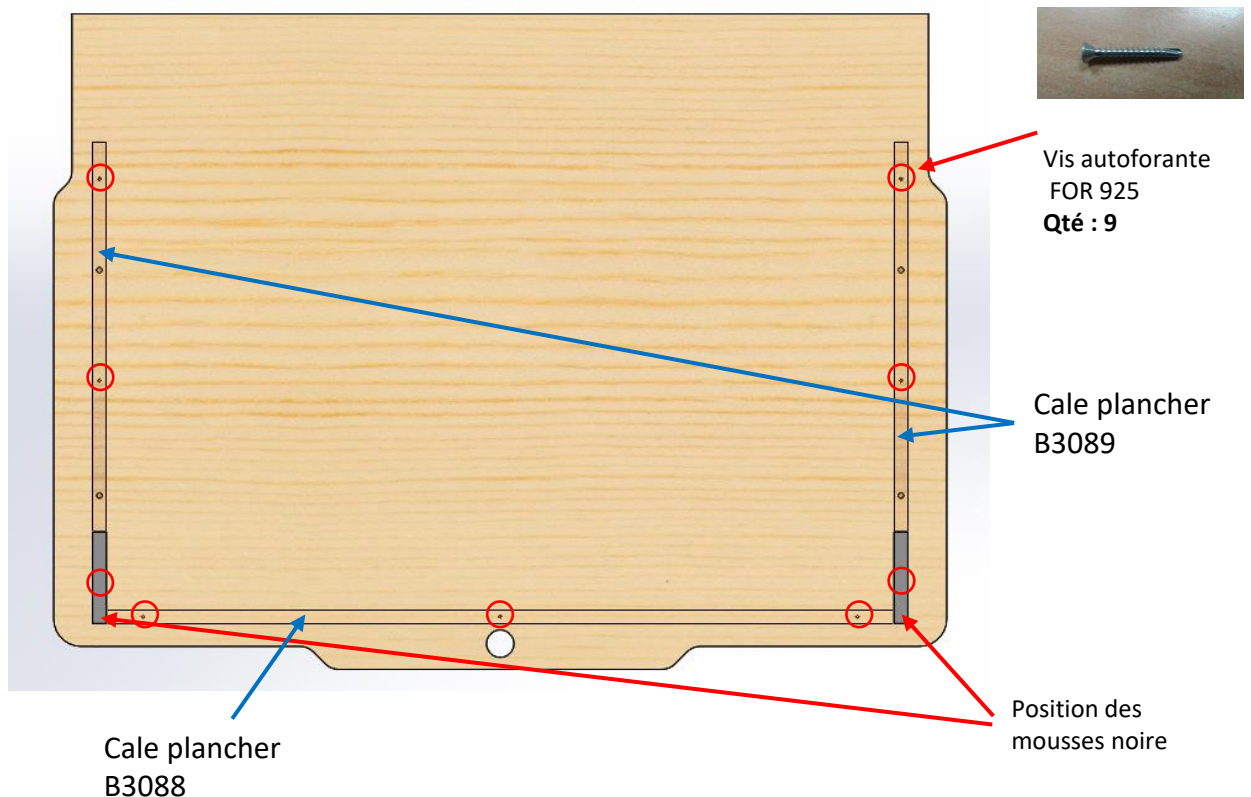
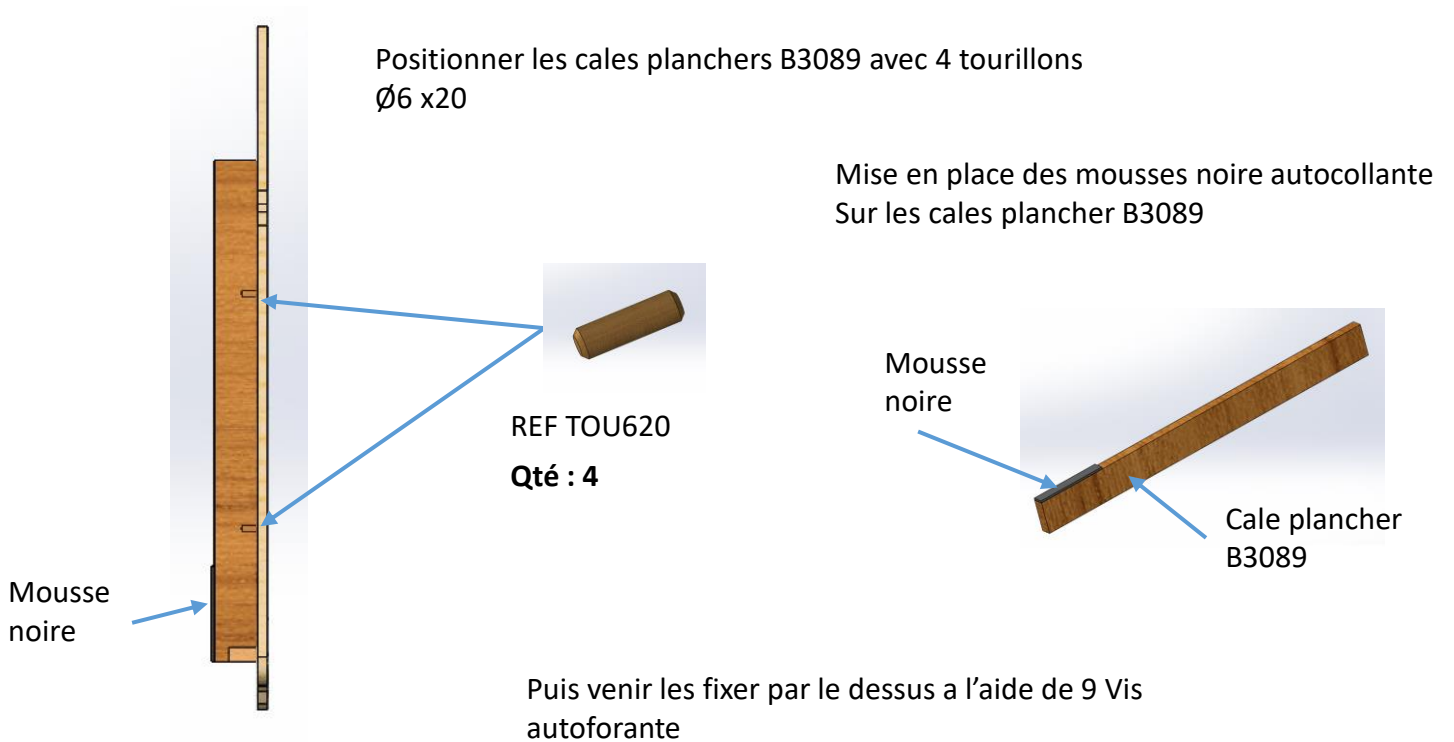

## KIT SOCIETE ARRET DE CHARGES

### 12) Montage des planchers bois B3085 et B3086



Vis autoforante  
FOR 925  
Qté : 12



Vis charnière  
FOR 295  
Qté : 8



Charnière  
CHARNIERE PLANCHER  
Qté : 4

### 10 ) Mise en place de la moquette M3090



Moquette M3090

## KIT SOCIETE ARRET DE CHARGES

### 11) Mise en place de 2 anneaux d'arrimage

Fixation des 2 anneaux d'arrimage  
avec 2 vis poêlier M6x16

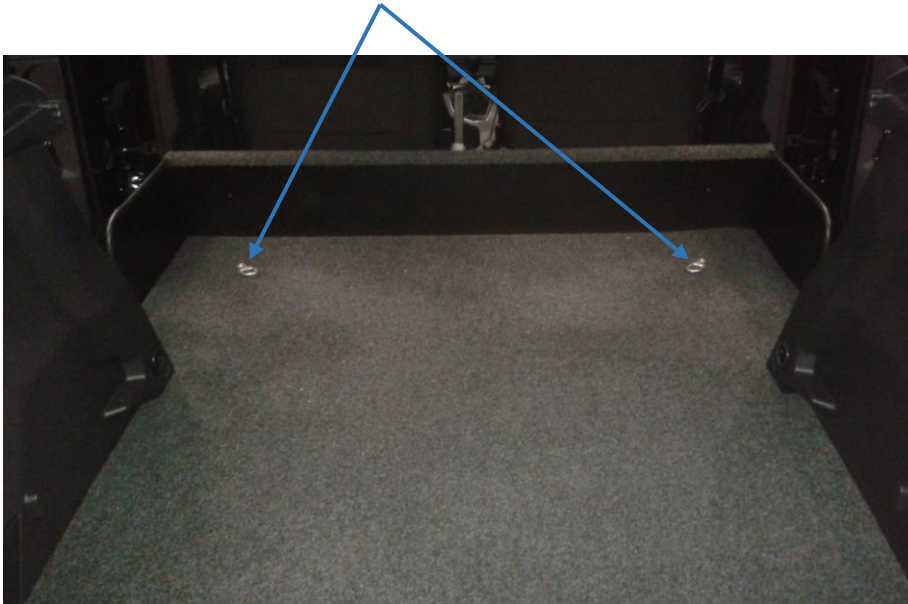

REF PLOVP 616 Z  
Qté : 2



Anneaux d'arrimage  
Qté : 2

### 12 ) Coller la plaque de transformation :

Depuis le 1<sup>er</sup> Juillet 2015, date d'entrée en vigueur de l'arrêté du 7 Novembre 2014, il n'y a plus ni plaque de tare ni plaque de chargement à apposer sur un véhicule transformé en VASP

## KIT SOCIETE ARRET DE CHARGES

**LA PLAQUE AUTOCOLLANTE EST EXPEDIEE AVEC LE KIT.  
(DANS LE SACHET DE VISSERIE)**

COLLER LA PLAQUE DE TRANSFORMATION A PROXIMITE DE LA PLAQUE CONSTRUCTEUR

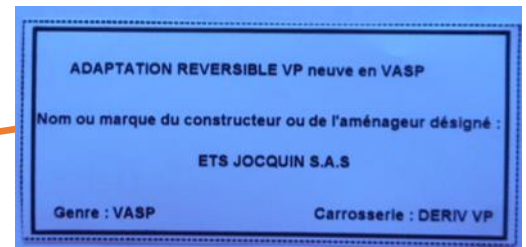

**13 ) Nettoyer le véhicule**



MARQUE DU VEHICULE :	
TYPE DU VEHICULE :	
N° de CLEF du VEHICULE :	

IFAB111  
INDICE A

	OPERATION	Conforme C	Non conforme NC	OBSERVATIONS
1	RECEPTION DU VEHICULE VERIFIER N° SERIE	C	NC	
2	CONTRÔLE DU KIT	C	NC	
3	PRESENCE NOTICE MONTAGE	C	NC	
4	DEMONTAGE des EQUIPEMENTS SELON MODE OPERATEUR	C	NC	
5	PREPARATION DE L'HABITACLE Ex : vis pastilles joints	C	NC	
6	MONTAGE STRUCTURE METALLIQUE ARRET DE CHARGE	C	NC	
7	FIXATION DU PLANCHER SELON COUPLE DE SERRAGE	C	NC	
8	POSE DE LA MOQUETTE VERIFIER L'ETAT	C	NC	
9	INSTALLATION ELEMENTS FINITION Vérifier : caches, carres de moquette, anneau arrimage	C	NC	
10	POSE DE L'ETIQUETTE VASP	C	NC	
11	NETTOYAGE DU VEHICULE	C	NC	

NOM DU MONTEUR :	
DATE DE L'INTERVENTION :	
SIGNATURE DU MONTEUR :	

CACHET DU CARROSSIER / GARAGISTE :

**KIT SOCIETE ARRET DE CHARGES**

**ATTENTION** : Les cotes de chargement sont données  
Sans les banquettes arrières

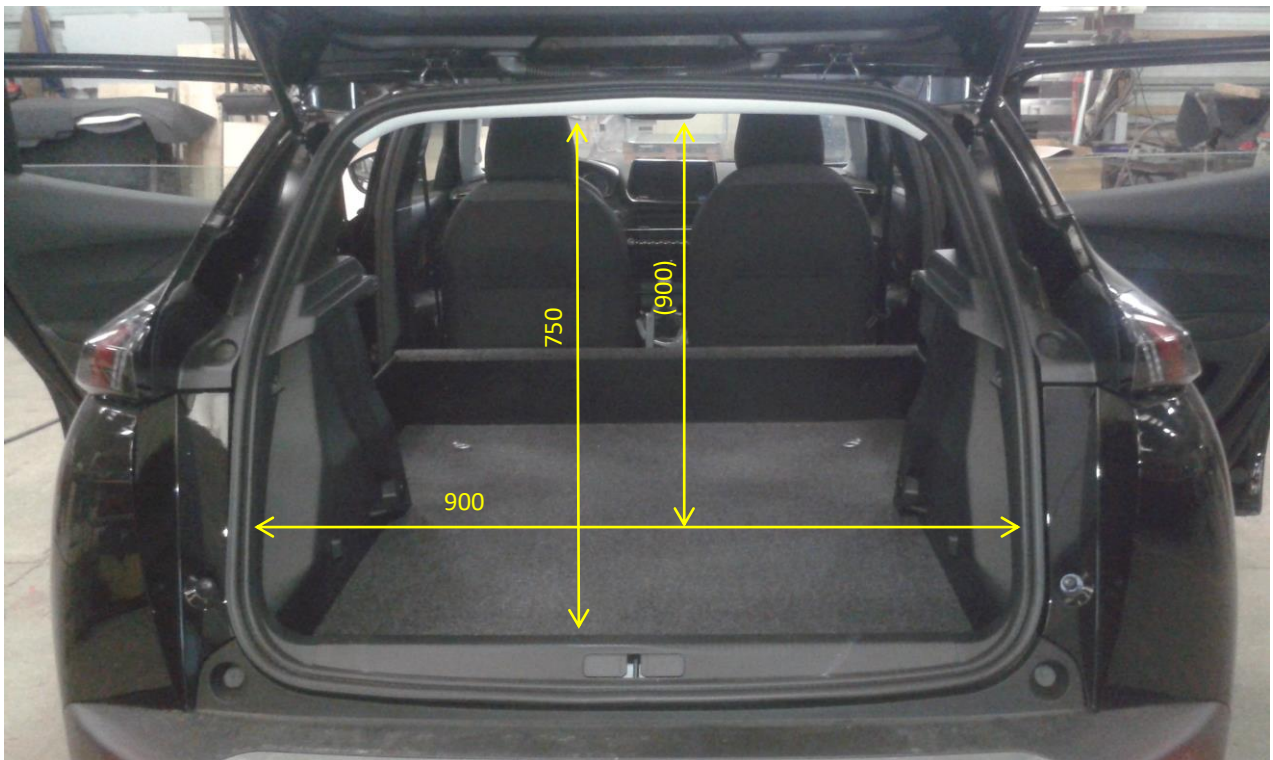
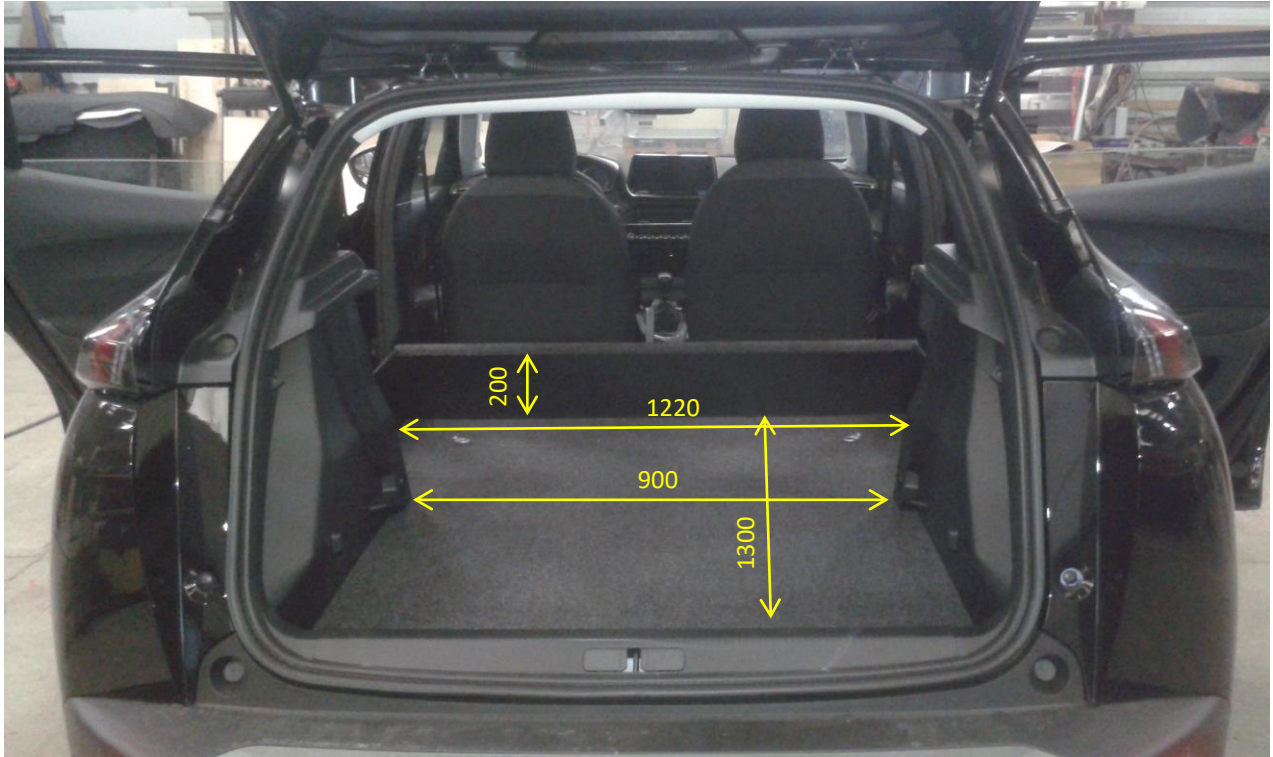

( 900 ) hauteur intérieure plancher / plafond

Masse ensemble banquette : 22 Kg

Masse ensemble Kit société : 22 Kg