

REF DU DOCUMENT : N0500 MI28042016 ASX

IFAB112

M.A.J Le : 14/11/2022

Indice de modif : Ind A

dessinateur : JR



**MITSUBISHI**

**ASX**





KIT SOCIETE ARRET DE CHARGE

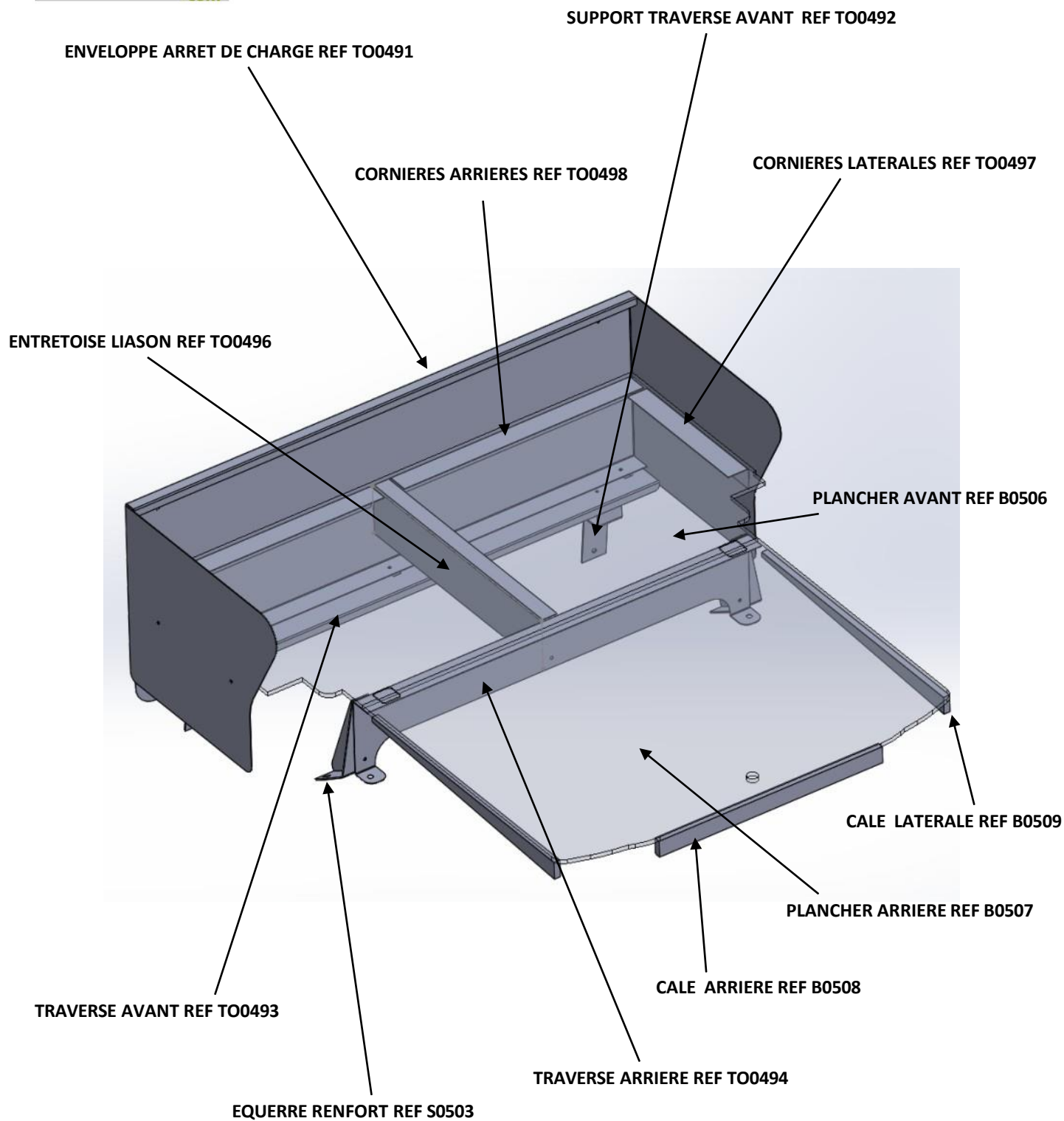

**COMPOSITION DU COLIS**

REF	DESIGNATION	QTE
TO0491	ENVELOPPE ARRET DE CHARGE	1
TO0492	SUPPORT TRAVERSE AVANT	2
TO0493	TRAVERSE AVANT	1
TO0494	TRAVERSE ARRIERE	1
TO0496	NETRETOISE LIAISON TRAVERSE AV / TRAVERSE AR	1
S0503	EQUERRE RENFORT TRAVERSE ARRIERE	2
TO0497	CORNIERE LATERALE SUPPORT PLANCHER	2
TO0498	CORNIERE ARRIERE SUPPORT PLANCHER	2
B0506	PLANCHER AVANT	1
B0507	PLANCHER ARRIERE	1
N0500	NOTICE DE MONTAGE	1
V0501	SACHET DE VISSERIE ( VOIR COMPOSITION TABLEAU CI-DESSOUS)	1
M0512	MOQUETTE ARRET DE CHARGE	1
B0508	CALE ARRIERE PLANCHER ARRIERE	1
B0509	CALE LATERALE	2

REF	DESIGNATION	QTE
DEC164	ANNEAU ARRIMAGE	2
PLOVP6X16	VIS POELIER 6X16 Z	2
PLO625	VIS POELIER 6X25 TETE NOIRE	10
PLOTE6	ECROU 6 TENSILOCK	16
PLOMU6	RONDELLE PLATE DIA 6	16
////	VIS BOIS 2.9 X 9.5	8
////	CHARNIERE PLASTIQUE	2
PLOVH6X16	VIS 6X16 TETE HEXA	11
FOR925	VIS TEC 3.9 X 25	10
FOR791	AGRAFES M6	3
////	ETIQUETTE AUTOCOLLANTE TRANSF VASP	1
	VIS BOIS 4x 20	11

Composition du sachet de visserie :

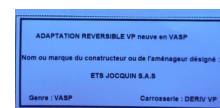

- 1) Réceptionner le véhicule et vérifier le N° de série .  
Placer le véhicule sur une aire de travail propre et stable.
- 2) Contrôler le kit .
- 3) Lire la notice de montage.
- 4) Démontez les équipements dans l'ordre suivant :

### ATTENTION

LA BATTERIE DU VEHICULE DOIT ETRE IMPERATIVEMENT  
DEBRANCHEE PENDANT LA DUREE DE L' INTERVENTION.

a ) Démontez les assises.

b ) Démontez les dossiers.

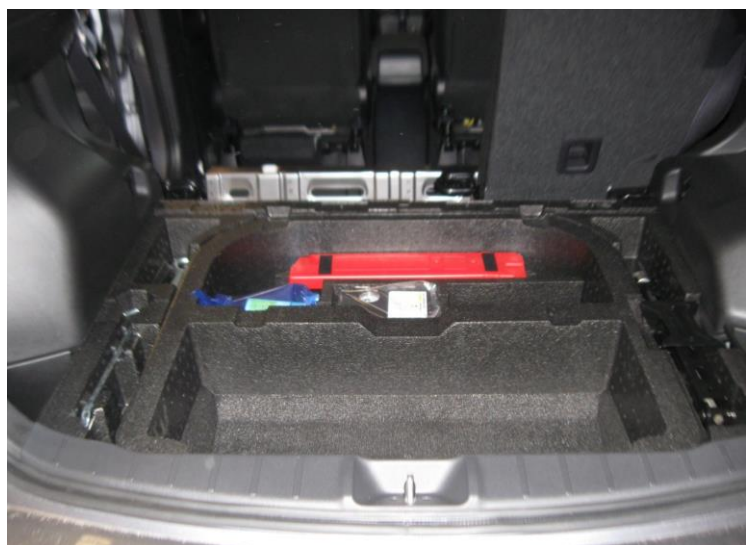

**ATTENTION POUR LE CONDITIONNEMENT DES CEINTURES IL EST IMPERATIF DE LAISSER \_ 70 cm DE GARDE POUR EVITER LE BLOCAGE DEFINITIF DU SYSTEME D'ENROULEUR .**

c) Enlever les coffres de rangement.

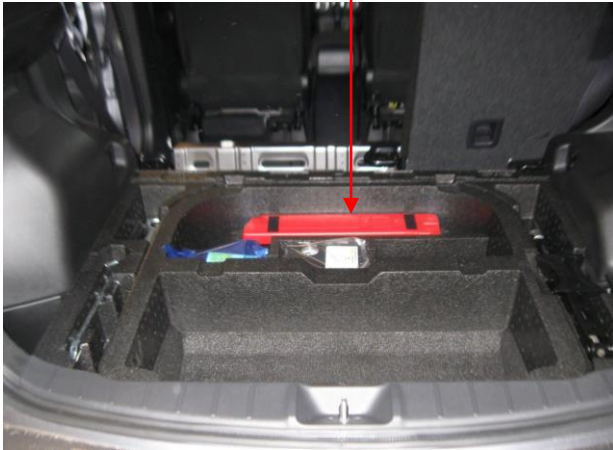

b) Démontez les ceintures.



e) Démontez les garnitures.

f) Démontez les ceintures.



Laissez cet élément uniquement  
Si l'installation d'un couvre bagages  
est prévue.



G ) Démonter les blocs polystyrène .

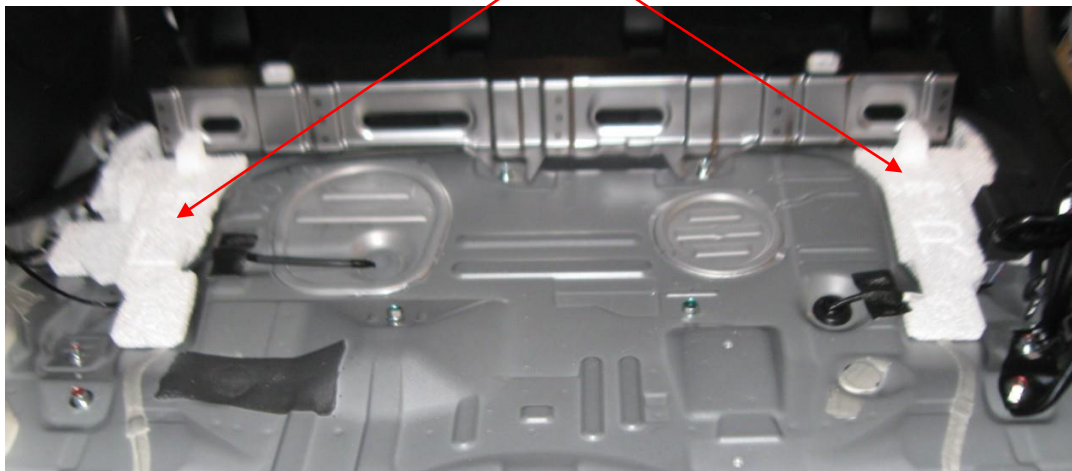

**Configuration du véhicule pour recevoir l'arrêt de charge**



5) Monter la structure métallique arrêt de charge dans l'ordre suivant :

a) Monter les 2 pattes avec les vis d'origine du véhicule.



Emplacement pour fixer la patte .



b) Fixer la traverse avant .

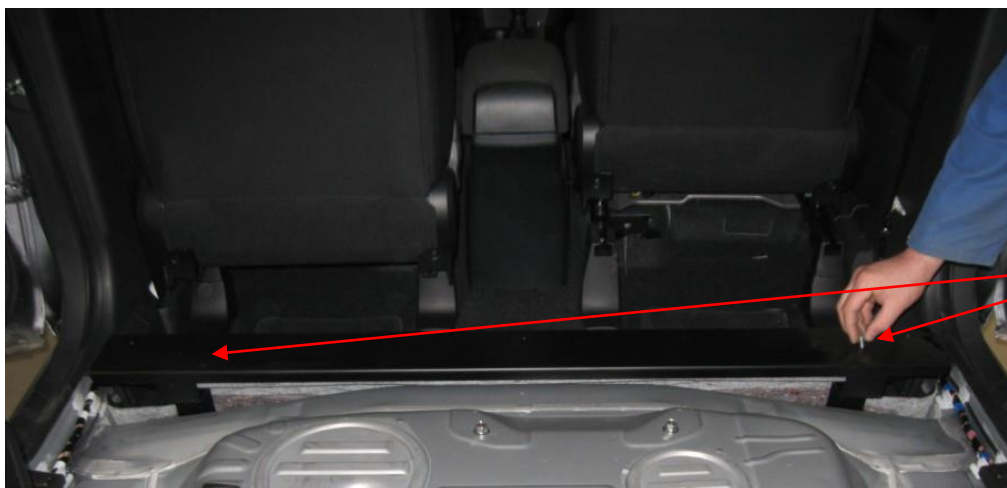

 2 x

c) Placer les 3 agrafes M6 sur les diamètres 7 de la traverse avant .

3 x

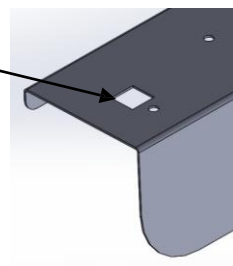

d) Fixer la traverse arrière avec les vis d'origine.

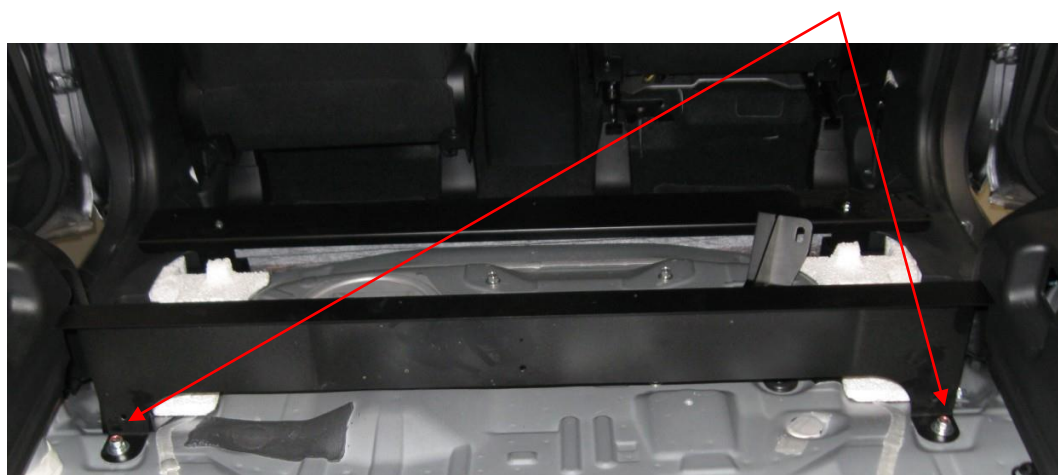

e) Fixer les équerres .

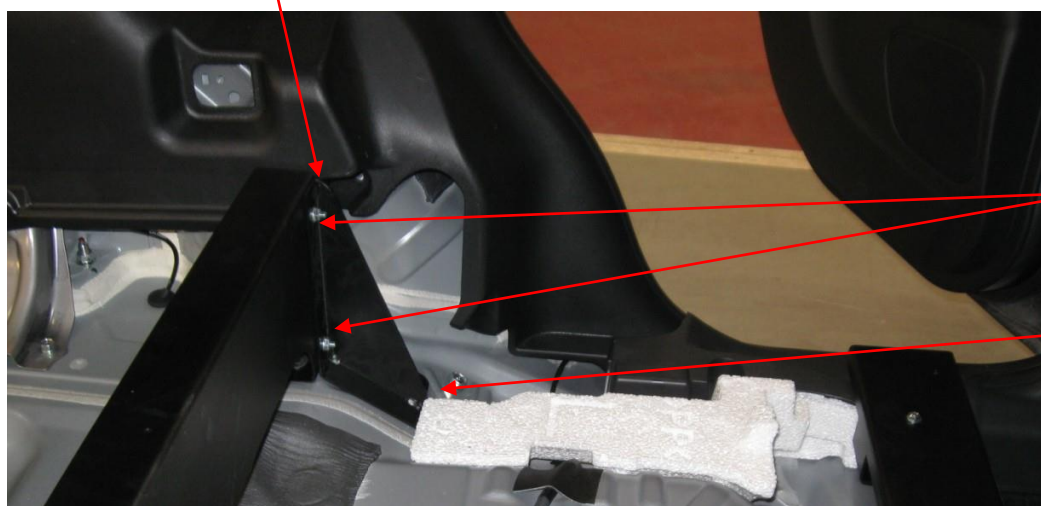

4 x



VIS D'ORIGINE

f) Fixer l'enveloppe arrêt de charge .



3 x





g) Fixer les cornières .

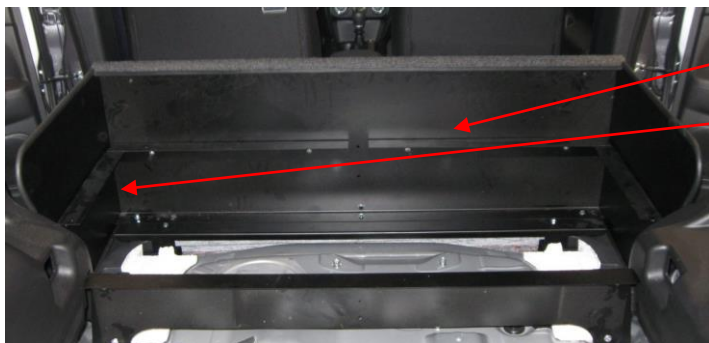

CORNIERES ARRIERES REF T00498 QTE 2

CORNIERES LATERALES REF T00497 QTE 2

8 x



h) Fixer l'entretoise .

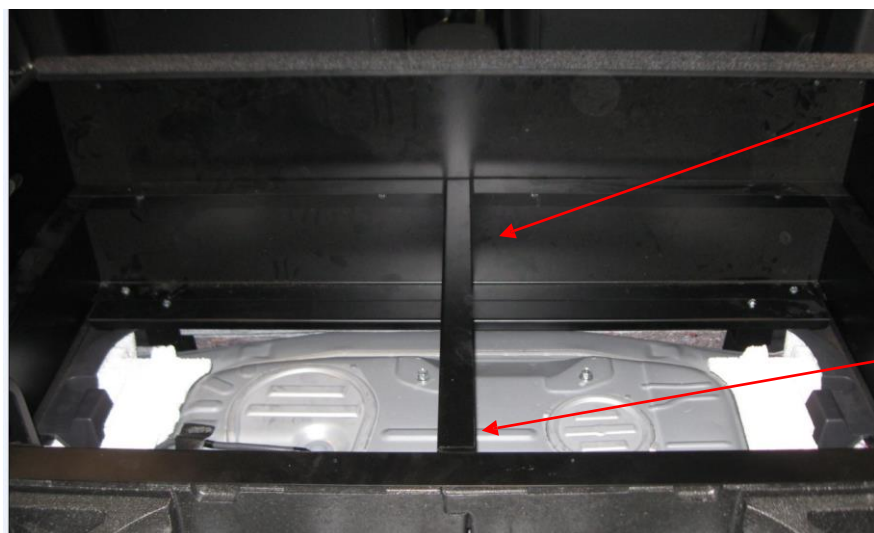

2 x

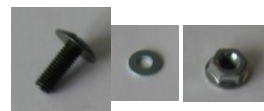

2 x



i) Préparation plancher arrière REF B0507.

Calle laterale

REF B0509

4x



Calle  
larriere

3x

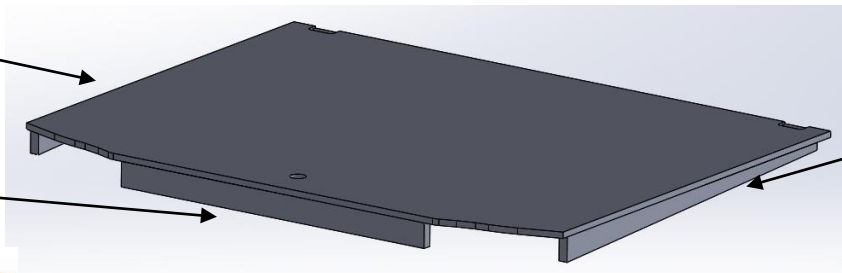

Calle laterale

REF B0509

4x



j) Fixer le plancher avant. 10 x



k) Placer le plancher arrière.



l) Fixer les charnières.



8 VIS BOIS 2.9X9.5

2 x



8 x



m) Positionner la moquette.



n) Fixer les anneaux d'arrimage.

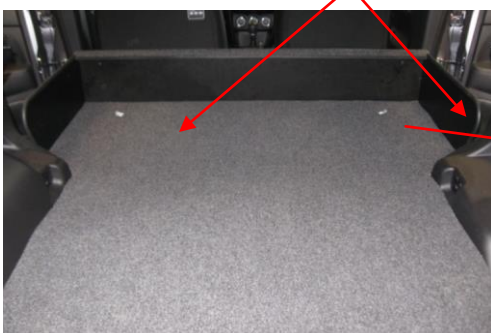

2 x

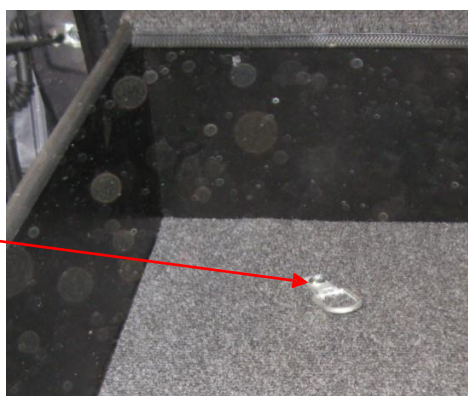

Depuis le 1<sup>er</sup> Juillet 2015 , date d'entrée en vigueur de l'arrêté du 7 Novembre 2014 , il n'y a plus ni plaque de tare ni plaque de chargement a apposer sur un véhicule transformé en VASP.

6 ) Coller la plaque de transformation :

**LA PLAQUE AUTOCOLLANTE EST EXPEDIEE AVEC LE KIT .  
( DANS LE SACHET DE VISSERIE )**

COLLER LA PLAQUE DE TRANSFORMATION A PROXIMITE DE LA PLAQUE CONSTRUCTEUR.



7 ) Nettoyer le véhicule.



MARQUE DU VEHICULE :	
TYPE DU VEHICULE :	
N° de CLEF du VEHICULE :	

IFAB111

INDICE A

	OPERATION	Conforme	Non conforme	OBSERVATIONS
		C	NC	
1	RECEPTION DU VEHICULE VERIFIER N° SERIE	C	NC	
2	CONTRÔLE DU KIT	C	NC	
3	PRESENCE NOTICE MONTAGE	C	NC	
4	DEMONTAGE des EQUIPEMENTS SELON MODE OPERATEUR	C	NC	
5	PREPARATION DE L'HABITACLE Ex : vis pastilles joints	C	NC	
6	MONTAGE STRUCTURE METALLIQUE ARRET DE CHARGE	C	NC	
7	FIXATION DU PLANCHER SELON COUPLE DE SERRAGE	C	NC	
8	POSE DE LA MOQUETTE VERIFIER L'ETAT	C	NC	
9	INSTALLATION ELEMENTS FINITION Vérifier : caches, carres de moquette, anneau arrimage	C	NC	
10	POSE DE L'ETIQUETTE VASP	C	NC	
11	NETTOYAGE DU VEHICULE	C	NC	

NOM DU MONTEUR :	
DATE DE L'INTERVENTION :	
SIGNATURE DU MONTEUR :	

CACHET DU CARROSSIER / GARAGISTE :

